



Instructions for completing the Domestic wastewater permit application

TABLE OF CONTENTS

Purpose	-1-
Objectives	-1-
Statutory and Regulatory Citations	-1-
Abbreviations and Acronyms	-1-
Definitions	-2-
Who Should Apply For A Wastewater Permit?	-13-
When Is The Application Submitted?	-13-
How Is The Application Submitted?	-13-
How Much Is The Application Fee?	-14-
How Do I Obtain More Information?	-16-
How Do I Submit The Application?	-16-
Instructions for Administrative Report 1.0	-18-
Applicant Information	-18-
Contact Information	-21-
Notice Information	-22-
Regulated Entity and Permitted Site Information	-24-
Discharge/ Disposal Information	-27-
Miscellaneous Information	-30-
Signature Page	-31-
Instructions for Administrative Report 1.1 - New and Amendment	-32-
Affected Landowner Information	-32-
Buffer Zone	-34-
Original Photographs	-37-
Supplemental Permit Information Form	-38-
Instructions for Technical Report 1.0	-39-
Permitted and/or Proposed Flow	-39-
SIC Code	-39-
Treatment Units	-40-
Pollutant Analysis of Treated Effluent	-40-
Facility Operator	-41-
Sewage Sludge Management And Disposal	-41-
Permit Authorization For Sewage Sludge Disposal	-41-
Sewage Sludge Solids Management Plan	-42-
Sewage Sludge Lagoons	-43-
Requirements/Compliance/Enforcement	-44-
Unbuilt Phases	-44-
Site Drawing	-45-
RCRA/CERCLA/Other Wastes	-45-
Instructions For Technical Report 1.1 - New And Amendment	-46-
Permitted And/or Proposed Flows	-46-
Proposed Organic Loading	-47-
Proposed Effluent Quality And Proposed Disinfection	-48-
Design Calculations	-48-
Facility Site	-48-
Authorization for Sewage Sludge Disposal	-48-

Sewage Sludge Solids Management Plan	-49-
Worksheets to the Permit Application Technical Report	-50-
Instructions for Worksheet 2.0 - Receiving Waters	-52-
Domestic Drinking Water Supply	-52-
Discharge into Tidally Affected Water	-52-
Classified Segment	-52-
Description of Immediate Receiving Waters	-53-
General Characteristics of Water Body	-53-
Instructions For Worksheet 2.1 - Stream Physical Characteristics Worksheet	-54-
Data Collection	-54-
Summarize Measurements	-54-
Instructions for Worksheet 3.0 - Land Application of Effluent	-56-
Type of Application System	-56-
Land Application Area	-56-
Storage and Evaporation Ponds	-56-
Flood and Run on Protection	-56-
Annual Cropping Plan	-57-
Well and Map Information	-57-
Soil Map and Soil Analyses	-58-
Effluent Monitoring Data	-58-
Instructions for Worksheet 3.1 - Surface Disposal of Effluent	-59-
Land Application Requirements	-59-
Edwards Aquifer Recharge Area	-60-
Instructions for Worksheet 3.2 - Subsurface Land Disposal of Effluent	-61-
Subsurface Application	-61-
Edwards Aquifer Recharge Area	-61-
Instructions for Worksheet 3.3- Subsurface Area Drip Dispersal Systems	-62-
Subsurface Area Drip Dispersal System	-62-
Required Plans	-62-
Floodway Designation	-63-
Surface Waters in the State	-63-
Edwards Aquifer Recharge Area	-63-
Instructions for Worksheet 4.0 - Pollutant Analyses Requirements	-64-
Table 1	-65-
Table 2	-65-
Table 3	-65-
Instructions for Worksheet 5.0 - Toxicity Testing Requirements	-69-
Instructions for Worksheet 6.0 - Industrial Waste Contribution	-70-
All POTWs	-70-
POTWs with a Program or Required to Develop a Program	-70-
Significant Industrial User Information	-71-
Instructions for Worksheet 7.0 - Class V Injection Well	-72-
Example 1 - Common Process or Process Modifications	-74-
Example 2 - Common Treatment Units	-76-
Example 3 - Flow Diagram	-77-
Example 4 -Design Calculations and Plant Design Features	-78-
Example 5 - Sludge Management Plan	-82-

Example 6 - EPA Effluent Categorical Guidelines	-83-
Example 7 -Adjacent and Downstream Landowner Map	-84-
Example 8 - Buffer Zone Map	-86-
Example 9 -Water Balance and Storage Calculation	-87-

**Texas Commission on Environmental Quality
Wastewater Permitting Section**

Domestic Wastewater Permit Application

PURPOSE

Industrial facilities which generate wastewater may use this application to apply for a permit to discharge and/or dispose of wastewater.

OBJECTIVES

Use of these instructions will answer the following questions.

- Who must complete and submit an application?
- When must the completed application be submitted?
- How do I complete the application?
- How do I get more information and assistance in completing the application?

STATUTORY CITATIONS

Texas Water Code Chapters 5 and 26
40 Code of Federal Regulations

PRIMARY REGULATORY CITATIONS

All Chapters are found within Title 30 of the Texas Administrative Code

Chapter 21	Chapter 307
Chapter 39	Chapter 309
Chapter 40	Chapter 308
Chapter 50	Chapter 309
Chapter 55	Chapter 311
Chapter 60	Chapter 312
Chapter 80	Chapter 314
Chapter 213	Chapter 319
Chapter 217	Chapter 325
Chapter 222	Chapter 332
Chapter 281	Chapter 351
Chapter 305	

ABBREVIATIONS AND ACRONYMS

AMU - Agricultural Management Unit
BOD₅ - Biochemical Oxygen Demand (5-day)
CAFO - Confined Animal Feeding Operation
CASRN - Chemical Abstract Service Registration Number
CBOD₅ - Carbonaceous Biochemical Oxygen Demand (5-day)
CFR - Code of Federal Regulations
CIU - Categorical Industrial User
DMR - Discharge Monitoring Report
DO - Dissolved Oxygen
EPA - Environmental Protection Agency
IU - Industrial User
MAL - Minimum Analytical Level

ABBREVIATIONS AND ACRONYMS (CONTINUED)

MER - Monthly Effluent Report
MGD - Million Gallons per Day
MLSS - Mixed Liquor Suspended Solids
mg/L - Milligrams per Liter
µg/L - Micrograms per Liter
NPDES - National Pollutant Discharge Elimination System
NH₃-N - Ammonia Nitrogen
OCC - Office of the Chief Clerk
P2 - Pollution Prevention
POTW - Publicly Owned Treatment Works
QA/QC - Quality Assurance/Quality Control
SADDS - Subsurface Area Drip Dispersal System
SAR - Sodium Adsorption Ratio
SPIF - Supplemental Permit Information Form
SIC - Standard Industrial Classification
SIU - Significant Industrial User
SWDA - Solid Waste Disposal Act
TAC - Texas Administrative Code
TBLL - Technically Based Local Limits
TLAP - Texas Land Application Permit
TMDL - Total Maximum Daily Load
TCEQ - Texas Commission on Environmental Quality
TPDES - Texas Pollutant Discharge Elimination System
TSS - Total Suspended Solids
USDA - United States Department of Agriculture
USGS - United States Geological Survey
WWTP - Wastewater Treatment Plant

DEFINITIONS

2-Hour Peak Flow – The maximum flow sustained for a two-hour period during the period of daily discharge.

303(d)-List - A list of water bodies identified as impaired or threatened in accordance with the Federal Clean Water Act Section 303(d).

Act of God - If a person can establish that an event that would otherwise be a violation of a permit, an order, the rules adopted by the Commission, or the Texas Water Code was caused solely by an act of God, war, strike, riot, or other catastrophe, the event is not a violation of that permit, order, rule, or statute.

Algae - Plants that lack true roots, stems, and leaves. Algae consists of nonvascular plants that attach to rock and debris in the water or are suspended in the water column. Such plants may be green, blue-green, or olive in color, slimy to the touch, and usually have a coarse filamentous structure.

Annual Average Flow - The arithmetic average of all daily flow determinations taken within the preceding 12 consecutive calendar months.

Aquatic Macrophyte - Vascular plants that usually are arranged in zones corresponding closely to successively greater depths in shallow water. The characteristic plant forms that dominate these gradients (in order of decreasing depth) are: (1) submersed rooted aquatics; (2) floating-leaved rooted aquatics; (3) immersed rooted aquatics; (4) marginal mats. Some vascular plants (like duckweed) may live unattached in the water and may occur anywhere on the water surface.

Biochemical Oxygen Demand (5-day) - The amount of dissolved oxygen consumed in five days by biological processes breaking down organic matter

Categorical Industrial User (CIU) - An industrial user that is subject to Categorical Pretreatment Standards according to 40 CFR §403.6 and 40 CFR Chapter I, Subchapter N, §405 - 471, which are technology-based standards developed by EPA setting industry-specific effluent limits. (A list of industrial categories subject to Categorical Pretreatment Standards is included in Worksheet 1.0.)

Classified Waters - Water bodies classified as segments with specific uses and criteria in Appendix A or D of 30 TAC §307.10 of the Texas Surface Water Quality Standards.

Class I Sludge Management Facility - Any publicly owned treatment works (POTW) identified under 40 CFR §403.10(a) as being required to have an approved pretreatment program and any other treatment works treating domestic sewage classified as a Class I sludge management facility by the regional administrator in conjunction with the executive director because of the potential for its sludge use or disposal practices to adversely affect public health and the environment.

Commercial User - Industrial Users who are not considered to be a significant single source of toxics because of their small size, generally low flow and insignificant pollutant levels or loadings, including but not limited to, radiator shops, car washes, small laundries, gasoline stations, dry cleaners and restaurants.

Commission - The Texas Commission on Environmental Quality

Composite Sample - A sample made up of a minimum of three effluent portions or as specified in 30 TAC §319.9 collected in a continuous 24-hour period or during the period of daily discharge if less than 24 hours, and combined in volumes proportional to flow, and collected no closer than two hours apart. For purposes of the TPDES Pretreatment Program, a composite sample is defined in 40 CFR §403, Appendix E.

Continuous Discharge - A “discharge” which occurs without interruption throughout the operating hours of the facility, except for infrequent shutdowns for maintenance, process changes, or other similar activities.

Daily Average Concentration - The arithmetic average of all effluent samples, composite or grab as required by a permit, within a period of one calendar month, consisting of at least four separate representative measurements.

Daily Average Flow - The arithmetic average of all determinations of the daily discharge within a period of one calendar month. The daily average flow determination shall consist of determinations made on at least four separate days. If instantaneous measurements are used to determine the daily discharge, the determination shall be the average of all instantaneous measurements taken during a 24-hour period or during the period of daily discharge if less than 24 hours. Daily average flow determination for intermittent discharges shall consist of a minimum of three flow determinations on days of discharge.

Design Flow - The wet weather maximum 30-day average flow of wastewater.

Disinfection - A chemical or physical process that kills pathogenic organisms in water.

Discharge Monitoring Report - The EPA uniform national form, including any subsequent additions, revisions, or modifications for the reporting of self-monitoring results by permittees. Permittees with TPDES permits are required to submit this form. Monitoring results must be reported on a approved TPDES self-report form, DMR Form EPA No. 3320-1, signed and certified.

Disposal - The disposal, deposit, injection, dumping, spilling, leaking, or placing of any solid, liquid, or hazardous waste into or on any land or water so that such waste or any constituent thereof may enter the environment or be emitted into the air or discharged into any waters, including groundwater.

Domestic sewage - Waste and wastewater from humans or household operations that is discharged to a wastewater collection system or otherwise enters a treatment works.

Effluent - Wastewater, treated or untreated, that flows out of a treatment plant sewer.

Effluent Limitations - Restrictions established by the TCEQ or EPA on quantities, rates, and concentrations in wastewater discharges.

Executive Director - The Executive Director of the Texas Commission on Environmental Quality or his/her designee.

Existing Facility - Any facility used for the storage, processing, or disposal of domestic wastewater and which has obtained approval of construction plans and specifications as of March 1, 1990.

Facility - All contiguous land and fixtures, structures, or appurtenances used for storing, processing, or disposing of waste. (See also the definition relating to sewage sludge.)

Fixture of the Land - An item that has become so annexed to the realty that it is regarded as part of the land (i.e., ponds, lagoons).

Glide - Portion of the water column that resembles flow that would be found in a shallow canal. Water surface gradient over a glide is nearly zero, so velocity is slow, but flow is shore to shore without eddy development.

Grab Sample - An individual sample collected in less than 15 minutes.

Industrial User - Any industrial or commercial facility that discharges wastewater to the treatment works that is not domestic wastewater. Domestic wastewater includes wastewater from connections to houses, hotels, non-industrial office buildings, institutions, or sanitary waste from industrial facilities. A non-regulated IU does not meet the definition of SIU or CIU.

Industrial wastewater - Wastewater generated in a commercial or industrial process.

Interference - A discharge that, alone or in conjunction with a discharge or discharges from other sources, both: (1) Inhibits or disrupts the treatment system, its treatment processes or operations, or its sludge processes, use or disposal; and (2) Therefore is a cause of a violation of any requirement of the facility's NPDES permit (including an increase in the magnitude or duration of a violation) or of the prevention of sewage sludge use or disposal in compliance with the following statutory provisions and regulations or permits issued thereunder (or more stringent State or local regulations): Section 405 of the Clean Water Act, the Solid Waste Disposal Act (SWDA) (including title II, more commonly referred to as the Resource Conservation and Recovery Act (RCRA), and including State regulations contained in any State sludge management plan prepared pursuant to subtitle D of the SWDA), the Clean Air Act, the Toxic Substances Control Act, and the Marine Protection, Research and Sanctuaries Act.

Intermittent Stream - A stream which has a period of zero flow for at least one week during most years. Where flow records are available, a stream with a two-year, seven-day flow of less than 0.1 cubic feet per second is considered intermittent.

Major Amendment of Permit - Any change that is not listed in 40 CFR §122.63 is considered a major amendment. A major amendment changes a substantive term, provision, requirement, or a limiting parameter of a permit.

Minimum Analytical Level - The lowest concentration at which a particular substance can be quantitatively measured with a defined precision level, using approved analytical methods. The minimum analytical level is not the published method detection limit for an EPA-approved analytical method, which is based on laboratory analysis of the substance in reagent (distilled) water. The minimum analytical level is based on analyses of the analyte in the matrix of concern (i.e., wastewater effluents). The commission will establish general minimum analytical levels that will be applicable when information on matrix-specific minimum analytical levels is unavailable.

Minor Amendment of Permit - An amendment to improve or maintain the permitted quality or method of disposal of waste or injection of fluid if there is neither a significant increase of the quantity of waste or fluid to be discharged or injected nor a material change in the pattern or place of discharge or injection. A minor amendment includes any other change to a permit issued under 30 TAC §305, Subchapter D that will not cause, or relax a standard or criterion which may result in a potential deterioration of quality of water in the state. A Minor amendment may also include, but is not limited to: except for TPDES permits, changing an interim compliance date in a schedule of compliance; provided the new date is not more than 120 days after the date specified in the existing permit and does not interfere with attainment of the final compliance date; and except for TPDES permits, requiring more frequent monitoring or reporting by the permittee.

Minor Modification of Permit - Under 40 CFR §122.63 and 30 TAC §305.62(c)(3), minor modification may only:

- (a) correct typographical errors
- (b) require more frequent monitoring or reporting by the permittee
- (c) change an interim compliance date in a schedule of compliance (not to exceed 120 days of date specified in existing permit and will not interfere with final compliance date); or
- (d) allow for a change in ownership or operational control of a facility where the Director determines that no other change in the permit is necessary.
- (e) (1) change the construction schedule for a discharger which is a new source;
(2) delete a point source outfall when the discharge from that outfall is terminated;
- (f) [reserved];
- (g) incorporate conditions of a POTW pretreatment program as enforceable conditions of the POTW's permits

Monthly Effluent Report - Facilities with Texas Land Application Permits or Sludge Permits are required to complete this form or equivalent.

National Pollutant Discharge Elimination System - The national program for issuing, amending, terminating, monitoring, and enforcing permits, and imposing and enforcing pretreatment requirements, under CWA, Sections 307, 402, 318, and 405. The term includes an approved program.

New Discharger - Any building, structure, facility or installation from which there is or may be a discharge of pollutants that did not commence the discharge of pollutants at a particular site prior to August 13, 1979, which is not a new source, and which has never received a finally effective NPDES permit for discharges at that site.

New Facility - Any domestic wastewater treatment facility which is not an existing facility.

Nuisance Odor Prevention - The reduction, treatment, and dispersal of potential odor conditions that interfere with another's use and enjoyment of property that are caused by or generated from a wastewater treatment plant unit, which conditions cannot be prevented by normal operation and maintenance procedures of the wastewater treatment unit.

Operator - The person responsible for the overall operation of a facility or beneficial use site.

Outfall - The point or location where waterborne waste discharges from a sewer system, treatment facility, or disposal system into or adjacent to water in the state.

Overhanging Vegetation - Vegetation that overhangs the water column and indirectly provides fish food and cover and shades the water from solar radiation.

Owner - The person who owns a facility or part of a facility.

Pass Through - A discharge which exits the POTW into waters of the United States in quantities or concentrations that, alone or in conjunction with a discharge or discharges from other sources, is a cause of a violation of any requirement of the POTW's NPDES permit (including an increase in the magnitude or duration of a violation)

Peak Flow - The highest two hour average flow rate expected to be delivered to the treatment units under any operational conditions, including periods of high rainfall (generally the two-year, 24 hour storm is assumed) and prolonged periods of wet weather.

Permit - A written document issued by the Commission which, by its conditions, may authorize the permittee to construct, install, modify, or operate, in accordance with stated limitations a specified facility for waste discharge, for solid waste storage, processing or disposal, or for underground injection.

Perennial Stream - Normally flowing stream.

Persistent Pools - Enduring pools containing sufficient habitat to maintain significant aquatic life uses.

Person - An individual, corporation, organization, government, governmental subdivision or agency, business trust, estate, partnership, or any other legal entity or association.

Pool - An area of the water column that has slow velocity and is deeper than a riffle, run, or glide. The water surface gradient of pools is very close to zero and their channel profile is usually concave. Pools often have eddies with varying directions of flow.

Process Wastewater - Any water which, during manufacturing or processing, comes into direct contact with or results from the production or use of any raw material, intermediate product, finished product, byproduct or waste product.

Publicly Owned Treatment Works (POTW) - Any device or system used in the treatment (including recycling and reclamation) of municipal sewage or industrial wastes of a liquid nature which is owned by the State or a municipality. This definition includes sewers, pipes, or other conveyances only if they convey wastewater to a POTW providing treatment.

Renewal of Permit - An extension of the effective date of a permit that authorizes the continued discharge or disposal of wastewater without changes in substantive term, provision, requirement, or limiting parameter of a permit.

Riffle - Portion of water column that is usually constricted where water velocity is fast due to a change in surface gradient. Stream depth is generally shallow and the channel profile is usually straight to convex. Surface flow through riffles usually ripples due to constriction, shallowness, and presence of irregular bottom substrates.

Riparian Zone - Area that includes the stream bank and flood plain.

Run - Portion of the water column that has rapid non-turbulent shore to shore flow. A run is too deep to be a riffle and flow is too fast to be a pool. The channel profile under a run is usually a uniform flat plane.

Significant Industrial User (SIU) - An industrial user defined in 40 CFR §403.3(t) as follows:

- Subject to Categorical Pretreatment Standards according to 40 CFR §403.6 and 40 CFR Chapter I, Subchapter N; and

- Any other industrial user that:
 - a. Discharges an average of 25,000 gallons per day or more of process wastewater to the treatment works (excluding sanitary, noncontact cooling and boiler blowdown wastewater);

Contributes a process waste stream that makes up 5 percent or more of the average dry weather hydraulic or organic capacity of the treatment works;
or
 - b. Is designated as such by the Control Authority as defined in 40 CFR §403.12(a) on the basis that the industrial user has a reasonable potential for adversely affecting the treatment works operation or for violating any pretreatment standard or requirement (according to 40 CFR §403.8(f)(6)).

Site - The land or water area where any facility or activity is physically located or conducted, including adjacent land used in connection with the facility or activity.

Stream Bend - Curved part of a stream. A well defined bend has a deep outside area and shallow inside area accentuated by point bar development. Due to sharp bending, stream flow is forced to the outside and eddies develop on the inside of the bend. A moderately developed bend forces some flow to the outside and has only a slight change in depth across the channel. A poorly defined bend has no noticeable change in water depth across the channel, and stream flow is generally not forced to one side.

Stream Depth - The vertical height of the water column from the existing water surface level to the channel bottom.

Stream Width - The horizontal distance along the transect line from shore to shore along the existing water surface.

Substantial Change in the Function or Use - An increase in the pollutant load or modification in the existing purpose of the unit.

Substrate - The mineral or organic material that forms the bottom of the stream.
Classification of substrate materials by particle size:

Bedrock		
Large Boulders	>17.7 in	(> 45 cm)
Boulders	9.8 - 17.7 in	(25 - 45 cm)
Rubble	2.4 - 9.8 in	(6 -25 cm)
Gravel	0.2 - 2.4 in	(6 - 60 mm)
Sand	0.002 -0.2 in	(0.06 - 6 mm)
Mud/Silt	<0.0002 in	(<0.06 mm)

Subsurface Area Drip Dispersal System - a waste dispersal system that 1) uniformly injects processed wastewater effluent into the ground at a depth of not more than 48 inches; and 2) spreads the waste over the entire disposal area so that the soil hydrologic absorption rate and crop/plant root absorption rate are not exceeded. The following systems are not subsurface area drip dispersal systems: 1) wastewater disposal systems authorized under Chapter 285 of this title (On-Site Sewage Facilities) and Texas Health and Safety Code 366; 2) disposal systems for oil and gas waste, tar sands, sulfur, brine from desalination plants and hazardous waste as defined by The Texas Health and Safety Code, Section 361.003; and/or 3) drainfields, leaching chambers, or other gravity trench systems.

Technically Based Local Limits - Specific discharge limits developed and enforced by POTWs upon industrial or commercial users to prevent interference and pass through and address the general and specific prohibitions, needs and concerns of a POTW. This will include consideration of its receiving waters, sludge contamination and/or worker health and safety problems.

Texas Land Application Permit - An authorization issued by the Commission for the discharge of waste adjacent to water in the state in compliance with the Texas Water Code.

Texas Pollutant Discharge Elimination System - The state program for issuing, amending, terminating, monitoring, and enforcing permits, and imposing and enforcing pretreatment requirements, under CWA, Sections 307, 402, 318, and 405, the Texas Water Code, and Texas Administrative Code regulations.

Total Dissolved Solids – A measure of the dissolved solids in wastewater or effluent.

Total Maximum Daily Load - The maximum amount of a pollutant that a lake, river, stream, or estuary can receive without seriously harming its beneficial uses. A detailed water quality assessment that provides the scientific foundation for a watershed action plan. A watershed action plan outlines the steps necessary to reduce pollutant loads in a certain body of water to restore and maintain uses or aquatic life.

Total Suspended Solids - A measure of the suspended solids in wastewater or effluent.

TPDES Wastewater Permit - An authorization issued by the Commission for the discharge of waste into water in the state in compliance with the Clean Water Act and the Texas Water Code.

Transect Line - A straight line, perpendicular to stream flow, between two points on opposite stream banks.

Treatment Facility (facility) - Wastewater facilities used in the conveyance, storage, treatment, recycling, reclamation and/or disposal of domestic sewage, industrial wastes, agriculture wastes, recreational wastes, or other wastes including sludge handling or disposal facilities under the jurisdiction of the Commission.

Tree Canopy - The uppermost spreading branchy layer of streamside trees that shades the water surface.

Unclassified Water - Smaller water bodies which are not designated as segments with specific uses and criteria in Appendix A or D of 30 TAC §307.10 of the Texas Surface Quality Standards.

Vascular - Relating to a channel for the conveyance of a body fluid or to a system of such channels; supplied with or made up of such channels and especially blood vessels.

Wastewater Treatment Plant Unit - Any apparatus necessary for the purpose of providing treatment of wastewater (i.e., aeration basins, splitter boxes, bar screens, sludge drying beds, clarifiers, overland flow sites, treatment ponds or basins that contain wastewater, etc.). For purposes of compliance with the requirements of 30 TAC §309.13(e) (relating to Unsuitable Characteristics), this definition does not include off-site bar screens, off-site lift stations, flow metering equipment, or post-aeration structures needed to meet permitted effluent minimum dissolved oxygen limitations.

Wetlands - Those areas that are inundated or saturated by surface water or groundwater at a frequency and duration to support, and that under normal circumstances do support, a prevalence of vegetation typically adapted for life in saturated soil conditions. Wetlands generally include swamps, marshes, bogs, and similar areas.

GENERAL DEFINITIONS RELATING TO SEWAGE SLUDGE DEFINED IN 30 TAC §312.8

Active Sludge unit - A sludge unit that has not closed and/or is still receiving sewage sludge.

Aerobic digestion - The biochemical decomposition of organic matter in sewage sludge into carbon dioxide, water and other by-products by microorganisms in the presence of free oxygen.

Agricultural Management Unit - A portion of land application area contained within an identifiable boundary, such as a river, fence, or road, where the area has a known crop or land use history.

Agronomic Rate - The whole sludge application rate (dry weight basis) designed: (A) to provide the amount of nitrogen needed by the crop or vegetation grown on the land; and (B) to minimize the amount of nitrogen in the sewage sludge that passes below the root zone of the crop or vegetation grown on the land to the groundwater.

Beneficial Use - Placement of sewage sludge onto land in a manner which complies with the requirements of 30 TAC 312 Subchapter B, and does not exceed the agronomic need or rate for a cover crop or any metal or toxic constituent limitations which the cover crop may have. Placement of sewage sludge on the land at a rate below the optimal agronomic rate will be considered a beneficial use.

Bulk Sewage Sludge - Sewage sludge that is not sold or given away in a bag or other container for application to the land.

Class A Sewage Sludge - Sewage sludge meeting one of the pathogen reduction requirements on 30 TAC §312.82(a).

Class B Sewage Sludge - Sewage sludge meeting one of the pathogen reduction requirements on 30 TAC §312.82(b).

Domestic Septage - Either liquid or solid material removed from a septic tank, cesspool, portable toilet, Type III marine sanitation device, or similar treatment works that receives only domestic sewage. Domestic septage does not include liquid or solid material removed from a septic tank, cesspool, or similar treatment works that receives either commercial wastewater or industrial wastewater and does not include grease removed from a grease trap.

Dry Weight Basis - Calculated on the basis of having been dried at 105 degrees Celsius until reaching a constant mass (i.e., essentially 100% solids content).

Facility - Includes all contiguous land, structures, other appurtenances, and improvements on the land used for the surface disposal, land application for beneficial use, or incineration of sewage sludge.

Groundwater - Water below the land surface in the saturated zone.

Land Application - The spraying or spreading of sewage sludge onto the land surface; the injection of sewage sludge below the land surface; or the incorporation of sewage sludge into the soil so that the sewage sludge can either condition the soil or fertilize crops or vegetation grown in the soil.

Monofill - A landfill trench in which sewage sludge is the only type of solid waste placed.

Off-site - Property which cannot be characterized as “on-site”.

On-site - The same or contiguous property owned, controlled or supervised by the same person. If the property is divided by public or private right-of-way, the access shall be by crossing the right-of-way or the right-of-way shall be under the control of the person.

Place Sewage Sludge or Sewage Sludge Placed - Disposal of sewage sludge on a surface disposal site.

Process or Processing - These terms shall have the same meaning as “treat” or “treatment”.

Saltwater - A coastal water which has a measurable elevation change due to normal tides. In the absence of tidal information, saltwater is generally considered to be a coastal water which typically has a salinity of two parts per thousand or greater in a significant portion of the water column.

Sewage Sludge - Solid, semi-solid, or liquid residue generated during the treatment of domestic sewage in treatment works. Sewage sludge includes, but is not limited to, domestic septage, scum, or solids removed in primary, secondary, or advanced wastewater treatment processes; and material derived from sewage sludge. Sewage sludge does not include ash generated during the firing of sewage sludge in a sludge incinerator or grit and screenings generated during preliminary treatment of domestic sewage in a treatment works.

Sludge Unit - Land on which only sewage sludge is placed for disposal. A sludge unit shall be used for sewage sludge. This does not include land on which sewage sludge is either stored or treated.

Sludge Unit Boundary - The outermost perimeter of a surface disposal site.

Transporter - Any person who collects, conveys, or transport sewage sludge, water treatment plant sludge, grit trap waste, grease trap waste, chemical toilet waste and/or septage by roadway, ship, rail, or other means.

Treat of Treatment of Sewage Sludge - The preparation of sewage sludge for final use or disposal including thickening, stabilization, and dewatering. This does not include storage.

Vector Attraction - The characteristic of sewage sludge that attracts rodents, flies, mosquitos, or other organisms capable of transporting infectious agents.

Water Treatment Sludge - Sludge generated during the treatment of either surface water or groundwater for potable use, which is not an industrial solid waste as defined in 30 TAC §335.1.

Permit Application Forms

The new, major amendment, minor amendment, and renewal applications with instructions are available in Adobe Acrobat PDF format on the TCEQ web site:

http://www.tceq.state.tx.us/comm_exec/forms_pubs/search_forms.html

TCEQ Central Registry Core Data Form

The Core Data Form has been incorporated into this form. **Do not send a core data form to TCEQ.**

If you don't already have one, you will be assigned a Customer Number (CN) and Regulated Entity Number (RN). You can find the information on the Central Registry web site at:

<http://www12.tceq.state.tx.us/crpub/>.

You can search by the RN, CN, name (permittee), or permit number under the search field

Additional ID.

The customer (permittee) is responsible for providing current information to the TCEQ, and for updating all CN and RN data for all authorizations as changes occur.

WHO SHOULD APPLY FOR A WASTEWATER PERMIT?

The **owner(s)** of a municipal/domestic facility which generates wastewater seeking authorization from the TCEQ to 1) discharge wastewater into water in the state (TPDES) or 2) dispose of wastewater adjacent to waters in the state by irrigation, evaporation, or subsurface disposal (TLAP) must be the applicant for a permit. For TPDES permits, whoever has overall financial responsibility for the operation of the facility must submit the application for a permit as a co-permittee with the facility owner. The facility operator is not required to apply as co-permittee if they do not have overall financial responsibility of the facility operations.

This application is not applicable for entities seeking a municipal wastewater permit. A municipal wastewater permit application must be submitted in order to obtain a municipal wastewater permit. Entities seeking discharge from a reverse osmosis water treatment plant must apply for a municipal/domestic wastewater permit.

WHEN IS THE APPLICATION SUBMITTED?

For new and amendment applications, the completed application should be submitted at least 180 days before the date the proposed discharge or disposal is to occur. For renewal applications, the completed application must be submitted at least 180 days before the expiration date of the current permit.

HOW IS THE APPLICATION SUBMITTED?

One original and three copies of the entire application must be submitted. Please do not staple or bind the original application. Do not use plastic sleeves for the maps in the original application. Please indicate which applications are copies. Use the following addresses to deliver the application.

The regular mailing address is:

Texas Commission on Environmental Quality

Water Quality Division

Applications Review and Processing Team (MC148)

P.O. Box 13087

Austin, Texas 78711-3087

The hand delivery address is:

Texas Commission on Environmental Quality
Applications Review and Processing Team
Building F, Room 2101
12100 Park 35 Circle
Austin, Texas 78753

The express mail address is:

Executive Director
Applications Review and Processing Team (MC148)
Texas Commission on Environmental Quality
12100 Park 35 Circle
Austin, Texas 78753

HOW MUCH IS THE APPLICATION FEE?

Domestic Wastewater Permit Application fees are dependent on the size of the facility (Proposed and/or Permitted Annual/Daily Average Flow of Final Phase).

<u>Flow</u>	<u>New/Major Amendment</u>	<u>Renewal</u>
< .05 MGD	\$350.00	\$315.00
≥ .05 but < .10 MGD	\$550.00	\$515.00
≥ .10 but < .25 MGD	\$850.00	\$1,215.00
≥ .50 but < 1.0 MGD	\$1,650.00	\$1,615.00
≥ 1.0 MGD	\$2,050.00	\$2,015.00
Minor Amendment (any flow)	\$115.00	

Fees are associated with a Wastewater Discharge Permit

Payment of the fees may be made by check or money order payable to TCEQ, or through EPAY (electronic payment through the web). The permit requires two different fees.

1. Application Fee: This fee is required to be paid at the time the application is submitted. Failure to submit payment at the time the application is filed will cause delays in acknowledgment or denial of coverage under the general permit.

Postage fees of \$50.00 for New and Amendments and \$15.00 for Renewals have been included with the application fees to cover the expense of the required notice (30 TAC §305.53). For new and major amendments the \$50.00 postage fee covers the expense of notifying up to one hundred (100) landowners. An additional \$50.00 postage fee will be required for each additional increment of up to one hundred (100) landowners.

To expedite the processing of the application, please provide a copy of the check with the application package. To verify receipt of payment or any other questions you may have regarding payment of fees to the TCEQ, please call the Revenues Section, Cashiers Office at (512) 239-0357. The applicant is responsible for the cost of publishing the public notice in the newspaper concerning the application for a permit. The applicant will be provided the information necessary to publish, including instructions, by Water Quality Applications Team for the first notice, and by the TCEQ Office of Chief Clerk for the second notice.

Mailed Payments

Payment must be mailed in a separate envelope to one of the addresses below. Include the attached Application Fee submittal form.

By regular U.S. mail

Texas Commission on Environmental Quality
Financial Administration Division
Cashier's Office, MC-214
P.O. Box 13088
Austin, TX 78711-3088

By overnight/express mail

Texas Commission on Environmental Quality
Financial Administration Division
Cashier's Office, MC-214
12100 Park 35 Circle
Austin, TX 78753

ePAY Electronic Payment

Go to: www.tceq.state.tx.us/epay

When making the payment you must select Water Quality, and then select the fee category Municipal. You must include a copy of the payment voucher with your application, which will not be considered complete without the payment voucher.

2. Annual Water Quality Fee: This fee is assessed to permittees with an active authorization on September 1 of each year. The permittee will receive an invoice for payment of the annual fee in November. The payment will be due 30 days from the invoice date. A 5% penalty will be assessed if the payment is not received by TCEQ by the due date. **Annual fee assessments cannot be waived as long as the permit is active on September 1.**

Important Note to all Applicants and Permittees: If your permit is in effect September 1, you will be assessed an annual Water Quality fee. It is the responsibility of the permittee to submit a cancellation or transfer form in a timely manner. Pursuant to 30 TAC Section 305.66, failure to pay fees is good cause for permit denial or revocation. If an applicant has outstanding fees, a proposed permit application will not be considered for approval by the Commission or Executive Director. For account balance information, contact the Financial Administration Division, Revenue Section, at (512) 239-0354.

Mailed Payments

Return your payment with the billing coupon provided with the billing statement.

By regular U.S. mail

Texas Commission on Environmental Quality
Financial Administration Division
Cashier's Office, MC-214
P.O. Box 13088
Austin, TX 78711-3088

By overnight/express mail

Texas Commission on Environmental Quality
Financial Administration Division
Cashier's Office, MC-214
12100 Park 35 Circle
Austin, TX 78753

ePAY Electronic Payment

Go to: www.tceq.state.tx.us/epay

Enter your account number provided at the top portion of your billing statement. Payment methods include MasterCard, Visa, and electronic check payment (ACH). A transaction over \$500 can only be made by ACH.

HOW DO I OBTAIN MORE INFORMATION?

Information on wastewater permitting and the municipal/domestic wastewater permit applications are available on the TCEQ web page at: <http://www.tceq.state.tx.us/nav/permits/iww.html>. Questions can also be directed to specific areas within the Water Quality Division:

Permit information and application forms	(512) 239-4671
Water Quality Applications Team, administrative information	(512) 239-4671
Municipal Permits Team, technical information	(512) 239-4671
Storm Water & Pretreatment Team, technical information	(512) 239-4671
Sludge/Transporter Team, technical information	(512) 239-3410
Environmental Law Division	(512) 239-0600
Stream survey and receiving water assessment	(512) 239-4671
Toxicity testing requirements	(512) 239-4671
Central Records, copies of records and permits on file	(512) 239-0900
TCEQ Publications	(512) 239-0028
Texas Secretary of State to obtain information on Charter Numbers	(512) 463-5555
State Comptroller of Texas to obtain Tax Identification	(800) 252-1386

The Texas Administrative Code can be viewed through the Texas Secretary of State and the TCEQ web sites. The address for the rules on the Secretary of State website is: [http://info.sos.state.tx.us/pls/pub/readtac\\$ext.viewtac](http://info.sos.state.tx.us/pls/pub/readtac$ext.viewtac). The address for the rules on the TCEQ website is <http://www.tceq.state.tx.us/rules>. Printed and diskette copies (in WordPerfect Format) of TCEQ rules are available through TCEQ Publications. The initial copy is free and the customer is allowed to reproduce as many additional copies as needed. Should the TCEQ be requested to reproduce additional copies, a fee will be charged as per General Services Commission Guidelines. The mailing address is: TCEQ Publications, MC 195, P.O. Box 13087, Austin, Texas 78711-3087. The telephone number is (512) 239-0028. The fax number is (512) 239-4488.

HOW DO I SUBMIT THE APPLICATION?

Submit the application when it is completed. **Only those sections and worksheets that are relevant should be submitted depending on the type(s) of authorizations being sought by the applicant.** Rarely will all sections and worksheets of the application be submitted. The Administrative Report 1.0 and Technical Report 1.0 must be submitted by all

applicants, while others, such as the Worksheet 3.0 (Land Disposal of Effluent) are used only when the applicant is requesting authorization to irrigate with treated effluent or another method of land disposal of effluent. **If there is a question as to which section must be submitted, please call the Wastewater Permitting Section.** When submitting the application, arrange the sections of the application as listed in the Submission Checklist. Indicate on the Submission Checklist which sections of the application have been submitted. Use the Table of Contents as Page 1 of the application for easier processing of the application.

If the answer to a question requires more space than is provided, submit a separate attachment to the question. The separate attachments must be clearly cross-referenced back to the original question. In the space provided the applicant's should write "See Attachment 1." Failure to clearly cross-reference attachments may result in delays in processing the application.

THE INSTRUCTIONS MUST BE FOLLOWED WHILE COMPLETING THE APPLICATION. THE INFORMATION BEING SUBMITTED WILL NOT BE CLEAR UNLESS THE INSTRUCTIONS ARE FOLLOWED. Each item in the application is cross referenced to a page number in the instructions. All items must be addressed. If an item is not addressed, a Notice of Deficiency letter will be sent to the applicant's representative unless an explanation is provided as to why the item is not applicable. Failure to follow the instructions while completing the application may result in significant delays in processing the application.

Applicant's are required to keep records of all data used to complete the permit application and any supplemental information submitted as part of the application process for a period of at least three years from the date the application is signed.

THE APPLICATION FORM MAY NOT BE ALTERED IN ANY WAY. APPLICATIONS THAT ARE NOT IN THE SAME FORMAT AND PAGE NUMBERING SEQUENCE WILL NOT BE PROCESSED AND WILL BE RETURNED. QUESTIONS CANNOT BE DELETED OR REARRANGED.

Please note: Older versions of the application forms will not be accepted after 6 months from the date of the updated or revised forms.

INSTRUCTIONS FOR DOMESTIC ADMINISTRATIVE REPORT 1.0

THE FOLLOWING ITEMS ARE REQUIRED FOR ALL PERMIT APPLICATIONS - RENEWALS, AMENDMENTS AND NEW. PLEASE READ THE INSTRUCTIONS CAREFULLY. FOLLOW WHILE COMPLETING THE APPLICATION.

Indicate by check mark the type of application being submitted. If submitting an amendment or modification to an existing permit, please describe the changes being requested (e.g., increasing flow from 0.1 to 0.2 MGD, decreasing the monitoring frequency, increasing the irrigation site acreage, adding an outfall, etc.).

1. APPLICANT INFORMATION

Important Note:

More than one entity may be required to apply for the permit as Co-Permittees.

The selected entity type indicates the name that must be provided as an applicant for a permit, registration or authorization. It also identifies when a co-applicant/co-permittee on an application for a permit, registration or authorization is required.

Partnership Not Filed with Texas Secretary of State

A customer that is established as a partnership as defined by the Texas Secretary of State's Office (TX SOS). If the customer is a 'general partnership' or 'joint venture' filed in the county (not filed with TX SOS), the legal name of each partner forming the 'general partnership' or 'joint venture' must be provided. Each 'legal entity' must apply as a co-applicant.

Trust or Estate

A trust and an estate are not legal entities, but rather are fiduciary relationships governing the trustee/executor with respect to the trust/estate property. A Trustee and an Executor are considered the legal representatives of the trust/estate. Therefore, the Trust and Trustee or Estate and Executor must be identified as co-applicants/co-permittees. If there is more than one trustee or executor, each trustee or executor must be identified as a co-applicant/co-permittee with the Trust or Estate.

a. Facility Owner (Applicant)

Legal Name

Provide the current legal name of the permittee, as authorized to do business in Texas. The name must be provided exactly as filed with the Texas Secretary of State (SOS), or on other legal documents forming the entity, that is filed in the county where doing business. You may contact the SOS at 512/463-5555, for more information related to filing in Texas. If filed in the county where doing business, provide a copy of the legal documents showing the legal name.

Enter assigned Customer Number (CN)

TCEQ's Central Registry will assign each customer a number that begins with "CN," followed by nine digits. **This is not a permit number**, registration number, or license number.

- If this customer has not been assigned a CN, leave the space for the CN blank.
- If this customer has already been assigned this number, enter the permittee's CN.

Enter the name and title of the person signing the application.

Mailing Address

Provide a complete mailing address for receiving mail from the TCEQ. The address must be verifiable with the US Postal Service at <http://www.usps.com> for regular mail delivery (not overnight express mail). If you find that the address is not verifiable using the USPS web search, please indicate the address is used by the USPS for regular mail delivery.

Phone Number

This number should correspond to this customer's mailing address given earlier. Enter the area code and phone number here. Leave *Extension* blank if this customer's phone system lacks this feature.

Fax Number and E-mail Address (Optional Information)

This number and E-mail address should correspond to applicant's mailing address provided earlier.

Indicate the type of Customer

Check only one box that identifies the type of entity. Use the descriptions below to identify the appropriate entity type.

Note that the selected entity type also indicates the name that must be provided as an applicant for a permit, registration or authorization. It also identifies when a co-applicant/co-permittee on an application for a permit, registration or authorization is required.

Sole Proprietorship – D.B.A.: a customer that is owned by only one person and has not been incorporated. This business may:

- be under the person's name
- have its own name ("doing business as" or d.b.a.)
- have any number of employees

If the customer is a Sole Proprietorship – D.B.A., the 'legal name' of the individual business 'owner' must be provided. The D.B.A. name is not recognized as the 'legal name' of the entity. The D.B.A. name may be used for the site name (regulated entity).

Individual (or DBA)

An individual is a customer who has not established a business, but conducts an activity that needs to be regulated by the TCEQ.

Partnership

A customer that is established as a partnership as defined by the Texas Secretary of State's Office (TX SOS).

If the customer is a 'general partnership' or 'joint venture' filed in the county (not filed with TX SOS), the legal name of each partner forming the 'general partnership' or 'joint venture' must be provided. Each 'legal entity' must apply as a co-applicant.

Corporation

A customer meets all of these conditions:

- is a legally incorporated entity under the laws of any state or country
- is recognized as a corporation by the Texas Secretary of State
- has proper operating authority to operate in Texas.

The corporation's 'legal name' as filed with the Texas Secretary of State must be provided as applicant. An 'assumed' name of a corporation is not recognized as the 'legal name' of the entity.

Government - Federal, state, county, or city government (as appropriate)

The customer is either an agency of one of these levels of government or the governmental body itself. The government agency's 'legal name' must be provided as the applicant. A department name or other description of the organization should not be included as a part the 'legal name' as applicant.

Trust or Estate

A trust and an estate are not legal entities, but rather are fiduciary relationships governing the trustee/executor with respect to the trust/estate property. A Trustee and an Executor are considered the legal representatives of the trust/estate. Therefore, the Trust and Trustee or Estate and Executor must be identified as co-applicants/co-permittees. If there is more than one trustee or executor, each trustee or executor must be identified as a co-applicant/co-permittee with the Trust or Estate.

Other

The customer does not fit any of the above descriptions. Enter a short description of the type of customer in the blank provided.

Independent Entity

Check *No* if this customer is a subsidiary, part of a larger company, or is a governmental entity. Otherwise, check *Yes*.

Number of Employees

Check one box to show the number of employees for this customer's entire company, at all locations. This is not necessarily the number of employees at the site named in the APPLICATION.

Customer Business Tax and Filing Numbers

State Franchise Tax ID Number

Corporations and limited liability companies that operate in Texas are issued a franchise tax identification number. If this customer is a corporation or limited liability company, enter this number here.

Federal Tax ID

All businesses, except for some small sole proprietors, individuals, or general partnerships should have a federal taxpayer identification number (TIN). Enter this number here. Use no prefixes, dashes, or hyphens. Sole proprietors, individuals, or general partnerships do not need to provide a federal tax ID.

TX SOS Charter (filing) Number

Corporations and Limited Partnerships required to register with the Texas Secretary of State are issued a charter or filing number. You may obtain further information by calling SOS at 512/463-5555.

DUNS Number

Most businesses have a DUNS (Data Universal Numbering System) number issued by Dun and Bradstreet Corp. If this customer has one, enter it here.

b. Co-Permittee Information

For TPDES permits, whoever has overall responsibility for the operation of the facility must submit the application for a permit as a co-permittee along with the facility owner. The facility operator is not required to apply as co-permittee if they do not have overall responsibility of the facility operations. If co-permittees are required, please indicate the address to be used on the permit and for permit correspondences (either the address provided for item 1.a or 1.b). See item 1.a for an example of the address should be completed in the application.

If the facility is considered a fixture of the land (e.g., ponds, units half-way in the ground), there are two options. The owner of the land can apply for the permit as a co-permittee or a copy of an executed deed recorded easement must be provided. The deed recorded easement must give the facility owner sufficient rights to the land for the operation of the treatment facility.

c. Individual Information

If the applicant is an individual, provide information on the individual as required by the Texas Water Code. Complete the address as shown above in item 1.a. The address provided must be the individual's home address. If the operator must apply as co-permittee and is an individual, provide a separate sheet for information on the operator. As the facility owner, you need to provide the Customer Reference Number (CN).

2. BILLING CONTACT INFORMATION

An annual fee is assessed to each permittee on September 1 of each year. Provide the complete mailing address where the annual fee invoice should be mailed. Verify the address with the USPS. It must be an address for delivery of regular mail, not overnight express mail. Also, provide a phone number of the permittee's representative responsible for payment of the invoice.

Country Mailing Information

If this address is outside the United States, enter the territory name, country code, and any non-ZIP mailing codes or other non-U.S. Postal Service features here. If this address is inside the United States, leave these spaces blank.

3. APPLICATION CONTACT INFORMATION

Provide the name, title and communication information of the person that TCEQ can contact for additional information regarding this application.

Below the name and address is a space to indicate by a check mark if the contact is either the Administrative and/or Technical contact. If the contact can answer administrative and technical questions, check both spaces. Two contacts may be provided in the application, one administrative and one technical. If additional contacts are provided, please provide a separate attachment to the application.

4. DMR CONTACT INFORMATION

Provide the name and mailing address of the person responsible for receiving and submitting DMRs. The preprinted DMRs will be provided by the TCEQ Enforcement Division unless you chose to submit electronically.

Submit data On Line.....



Submit on line through eDMR system. **Go to Sign up now at:**
<http://www.tceq.state.tx.us/permitting/steers/steers.html>
Establish an electronic reporting account when you get your permit number.

5. PERMIT CONTACT INFORMATION

Provide the names of two individuals that can be contacted by the agency as needed during the term of the permit. Include their phone number and mailing address if different than the permanent address used for the permit. The individuals should be of the level of Vice President or higher of a corporation, an Elected Official of a City or County, or a General Partner of a Partnership.

6. NOTICE INFORMATION

a. Individual publishing the notices

Provide the person's name, company name, mailing address, telephone number and fax number that will publish the notices required during the processing of the application. Only one person can be provided. This entity will be contacted to publish the required notices in a newspaper of the largest general circulation in the county where the facility is/will be located. This person must be available during the application processing since the first notice, the "Notice of Receipt of Application and Intent to Obtain a Water Quality Permit" must be published within 30 days of the application being declared Administratively Complete.

b. Method of receiving Notice of Receipt and Intent to Obtain a Water Quality Permit Package

Provide the method of receiving the required notice information (below item 3.c. on Administrative Report 1.0). The day the application is declared Administratively Complete the notice package will be sent to them via the method chosen by the applicant in the application. The notice package includes the TCEQ declaration of completeness, a notice ready for publication, instructions for publishing the notice, and a publication affidavit.

The second notice, "Notice of Application and Preliminary Decision" must be published within 30 days of a draft permit being filed with the Office of Chief Clerk (OCC). Detailed information may be obtained by referring to TCEQ's web site and 30 TAC Chapters 39, 50, 55, and 281 regarding notice, public comments, and response to comment procedures. All information necessary to publish the second notice, as well as proof of publication, will be mailed by the OCC. The address to mail the required information back to the TCEQ will be included in the information from the OCC. If the mailing address is a P.O. Box, insert the P.O. Box number within the space provided for the street name.

c. Contact in the Notice

Provide the person's name, company name, mailing address, telephone number and fax number of the one individual that will be identified as the notice contact in the two notices that are mailed out and published as part of the permitting process. This individual may be contacted by the public to answer general and specific questions about all aspects of the permit application. If the mailing address is a P.O. Box, insert the P.O. Box number within the space provided for the P.O. Box. Insert suite numbers within the line provided for the street name.

d. Public Place Information

Provide the name and physical address for the public place where the application information will be available for viewing and copying. The information requested in this portion of the application regards a public place where the complete application and draft permit and Technical Summary/Statement of Basis, and Fact Sheet, if applicable, must be made available for viewing and copying by the general public by the date the first notice is published. Please verify with the proper authority they will make the application available for public viewing and copying. The public place must be located within the county in which the facility is/will be located. The address must be a physical address. If the facility and or outfall is located in more than one county, a public viewing place for each county must be provided. **Post office box addresses are not acceptable.**

e. Bilingual Notice Requirements

Bilingual notice may be required for new permit applications, major amendment applications and renewal applications, (not applicable for minor amendment or minor modification applications). If an elementary school or middle school nearest to the facility offers a bilingual program, notice may be required to be published in an alternative language. The Texas Education Code, upon which the TCEQ alternative language notice requirements are based, triggers a bilingual education program to apply to an entire school district should the requisite alternative language speaking student population exist. However, there may not exist any bilingual-speaking students at a particular school within a district which is required to offer the bilingual education program. For this reason, the requirement to publish notice in an alternative language is triggered if the nearest elementary or middle school, as a part of a larger school district, is required to make a bilingual education program available to qualifying students and the school either has students enrolled at such a program on-site, or has students who attend such a program at another location in satisfaction of the school's obligation to provide such a program as a member of a triggered district.

The applicant is required to call the bilingual/ESL coordinator for the nearest elementary and middle schools and obtain information to determine if an alternative language notice is required. If it is determined that a bilingual notice is required, the applicant is responsible for ensuring that the publication in the alternate language is complete and accurate in that language.

7. REGULATED ENTITY AND PERMITTED SITE INFORMATION

Regulated Entity Reference Number (RN)

This is a number issued by TCEQ's Central Registry to sites (a location where a regulated activity occurs) regulated by TCEQ. This is not a permit number, registration number, or license number.

- If this regulated entity has not been assigned an RN, leave this space blank.
- If this customer has been assigned this number, enter the permittee's RN.

If the site of your business is part of a larger business site, a Regulated Entity Number (RN) may already be assigned for the larger site. Use the RN assigned for the larger site. Search TCEQ's Central Registry to see if the larger site may already be registered as a regulated site at: <http://www12.tceq.state.tx.us/crpub/index.cfm?fuseaction=regent.RNSearch>

If the site is found, provide the assigned Regulated Entity Reference Number and provide the information for the site to be authorized through this application below. The site information for this authorization may vary from the larger site information.

An example is a chemical plant where a unit is owned or operated by a separate corporation that is accessible by the same physical address of your unit or facility. Other examples include industrial parks identified by one common address but different corporations have control of defined areas within the site. In both cases, an RN would be assigned for the physical address location and the permitted sites would be identified separately under the same RN.

a. State/TPDES Permit No.

Provide the TCEQ Permit No. and the EPA Identification No. if the facility has an existing permit. For new facilities, this space should be marked N/A.

b. Name of the project or site

Provide the name of the site as known by the public in the area where the site is located. The name you provide on this application will be used in the TCEQ Central Registry as the Regulated Entity. An RN will be assigned by Central Registry if this site is not currently regulated by TCEQ.

c. Is the facility located in Bexar, Comal, Hays, Kinney, Medina, Travis, Uvalde, or Williamson County?

Indicate whether the facility is located in Bexar, Comal, Hays, Kinney, Medina, Travis, Uvalde, or Williamson County. These counties are listed since the Edwards Aquifer is located under the boundaries of these counties. If the facility is or will be located in one of these counties, 30 TAC §215, Edwards Aquifer Rules, may be applicable and the applicant may be required to provide additional information.

d. Site/Project (RE) Physical Address

Enter the complete address of where the site is located. This address must be validated through US Postal Service. If the physical address is not recognized as a USPS delivery address, you may need to validate the address with your local police (911 service) or through an online map site used to locate a site. Please confirm this to be a complete and valid address. Please do not use a rural route or post office box for a site location.

If a site does not have an address that includes a street (or house) number and street name, enter NO ADDRESS for the street name. Then provide a complete written location access description. For example: "The site is located 2 miles west from intersection of Hwy 290 & IH35, located on the southwest corner of the Hwy 290 South bound lane." Do not provide directions to the facility. The location description must use easily identifiable landmarks found on the USGS map submitted with the application. The description must include the direction and distance in feet or miles from road intersections. **If the existing permit includes an accurate description, indicate so by checking yes on the application form.** If, however, the application is for a new facility or the description is inaccurate, provide an accurate description. Two examples of acceptable location descriptions are: 1) The facility is located 2,600 feet southwest of the intersection of State Highway 20 and Farm-to-Market Road 1200; 2) The facility is located approximately 1.2 miles east of the intersection of Farm-to-Market Road 345 and County Road 10. **NOTE:** a new location requires a new (separate) permit - permits are site specific.

e. City where site is located or nearest city

Provide the name and distance to the nearest city from the location of the facility. The name of the nearest city is used by the commission to include that city on the notice mailing list.

f. Zip Code

Provide the zip code where the facility is located.

g. County where site is located

Identify the county or counties where the facility is located.

h. Latitude and Longitude

Enter the latitude and longitude of the site in degrees, minutes, and seconds or decimal form. For help obtaining the latitude and longitude, go to:

www.tceq.state.tx.us/gis/drgview.html or <http://msrmaps.com/advfind.aspx>

i. Description of Activity Regulated

In your own words, briefly describe the primary business that you are doing that requires this authorization. Do not repeat the SIC Code description.

j. Owner of treatment facility

Provide the name of the owner of the facility. **The plant owner must be the applicant for the permit (same as item 1).**

Indicate the type of facility. The owner of the facility is designated either public, private, both, or federal. A publicly owned treatment facility is **owned** by the state, unit of local government, or Indian Tribe, usually designed to treat domestic wastewaters. If the facility is **publicly owned, the applicant must complete Worksheet 6.0 of the technical report** (see Page 70 of the instructions). A privately owned treatment works is **owned** by a corporation, partnership, or other entity, and is not owned by a government entity. A facility designated as both is unusual, and is a combination of both public and private ownership.

k. Owner of land where treatment facility is/will be

Provide the name and mailing address of the owner of the land where the facility is located. If the mailing address is a P.O. Box, insert the P.O. Box number within the space provided. If the owner of the land is not the same as the applicant, a long term lease agreement for the life of the facility must be provided. A lease agreement can only be submitted if the facility is not a fixture of the land (e.g., above-ground package plant).

If the facility is considered a fixture of the land (e.g., ponds, units half-way in the ground), there are two options. The owner of the land can apply for the permit as a co-permittee or a copy of an executed deed recorded easement must be provided. A long term lease agreement is not sufficient if the facility is considered a fixture of the land.

Both the long term lease agreement and the deed recorded easement must give the facility owner sufficient rights to the land for the operation of the facility.

l. Owner of the effluent disposal site:

Provide the name and mailing address of the owner of the effluent disposal site (e.g., irrigation, evaporation), if applicable. If the mailing address is a P.O. Box, insert the P.O. Box number within the space provided. This item is only applicable for effluent disposal sites (e.g., irrigation, subsurface drip irrigation, evaporation). It is not for the point of discharge to the receiving waters. If the owner of the land is not the same as the applicant, a long term lease agreement must be provided. The lease agreement must give the facility owner uses of the land for effluent disposal. If the term of the lease agreement is less than five years, the permit may be drafted for a term equivalent to the term of the lease.

If ponds (i.e., holding ponds, evaporation ponds) are located on land not owned by the applicant, there are two options. The owner of the land can apply for the permit as a **co-permittee or a copy of an executed deed recorded easement must be provided.** The deed recorded easement must give the facility owner sufficient rights to the land for the operation of the facility and must be recorded in the county where the facility is located.

If the land is to be acquired by the facility owner, a copy of an executed option to purchase agreement must be submitted. The option to purchase must give a legal description of the land to be purchased and identify when the option to purchase agreement expires. An option to purchase may only be submitted with a new permit application.

m. Owner of the sewage sludge disposal site:

Provide the name and mailing address of the owner of the sewage sludge disposal site. The owner of the sewage sludge disposal site only needs to be provided if authorization for the disposal of sewage sludge on property owned or under the direct control of the applicant is being sought in the permit. If the owner of the land where the sewage sludge disposal site is located is not the same as the applicant, a long term lease agreement for at least the term of the permit must be provided. If sludge is hauled by a registered transporter to a separate site that is permitted or registered by the TCEQ, such as a municipal solid waste landfill or a registered land application site, ownership information does not need to be provided.

8. DISCHARGE/ DISPOSAL INFORMATION

The following information provides specific location information used in describing the location of the facility, the discharge route, the effluent disposal site, and other information relevant to the facility.

a. Point of discharge and discharge route:

Confirm whether the point of discharge and discharge route in the existing permit are correct by checking yes or no. **If the existing permit includes an accurate description, indicate so by checking yes on the application form** If no, please provide a description of the effluent discharge route. The discharge route must follow the flow of effluent from the point of discharge to the nearest major watercourse (from the point of discharge to a classified segment as defined in 30 TAC Chapter 307). . Two examples of a discharge route are: 1) through a six-inch pipe to a county drainage ditch; thence to Doe Creek; thence to the Brazos River, or; 2) from the plant site to an unnamed tributary of Joe Creek; thence to Joe Creek; thence to Quail Creek; thence to the Jane River Below Charles Lake. Classified segments can be found in 30 TAC Section 307.10 Appendix A and segment location descriptions can be found in 30 TAC Section 307.10 Appendix C. **The issuance of a permit does not grant a permittee the right to use the specific discharge route. The issuance of a permit does not grant the permittee the right to use private or public property for conveyance of wastewater along the discharge route described above. The permittee must acquire all property rights as may be necessary to use the discharge route.**

Please note: The relocation of the discharge point and/or discharge route may be subject to a Major Amendment to the permit.

b. City the outfall(s) located in:

Provide the city in which the outfall(s) are located in.

c. County the outfall(s) located in:

Provide the county or counties in which the outfall(s) are located in.

d. Latitude and Longitude

Enter the latitude and longitude of each outfall in degrees, minutes, and seconds or decimal form. For help obtaining the latitude and longitude, go to:

www.tceq.state.tx.us/gis/drgview.html or <http://msrmaps.com/advfind.aspx>

e. Daily discharge of 5 million gallons per day or more:

For all applications permitted for, or requesting an increase of 5 MGD or more, provide the name of each county or counties within 100 statute miles downstream of the point(s) of discharge.

f. Disposal site location:

If the existing permit includes an accurate description, indicate so by checking yes on the application form. If no, or a new site, provide a location description of the effluent disposal site (e.g., irrigation, subsurface drip irrigation, evaporation). Do not provide directions to the disposal site. The location description must use easily identifiable landmarks found on the USGS map submitted as an attachment to the application. The description must include the distance in feet or miles from road intersections. If, however, the application is for a new facility or the description is inaccurate, provide an accurate location description. Two examples of acceptable location descriptions are: 1) The effluent disposal site is located 2,600 feet southwest of the intersection of State Highway 20 and Farm-to-Market Road 1200; 2) The effluent disposal site is located 1.2 miles east of the intersection of Farm-to-Market Road 345 and

County Road 10. **NOTE:** a change in location or increase in acreage requires a major amendment.

g. City the disposal site located in:

Provide the city in which the disposal site is located in.

h. County the disposal site located in:

Provide the county or counties in which the disposal site is located in.

i. Latitude and Longitude of the disposal site:

Enter the latitude and longitude for the disposal site in degrees, minutes, and seconds or decimal form. For help obtaining the latitude and longitude, go to:

www.tceq.state.tx.us/gis/drgview.html or <http://msrmaps.com/advfind.aspx>

j. Effluent routing description:

Provide a description of how the treated effluent gets from the treatment facility to the effluent disposal site. An example of the flow of effluent to the disposal site is: from the treatment plant through a six-inch pipe to a one acre holding pond; thence via a four-inch pipe to the irrigation site. A major amendment to the permit is required in order to use an effluent disposal site different than the one described in an existing permit.

k. Nearest watercourse:

Provide the name of the nearest watercourse to the effluent disposal site to which rainfall runoff might flow if not contained within the disposal site. The name of the nearest watercourse for TLAP is included as part of the permit. This assists staff in determining the watershed in which the facility is/will be located.

l. Location of the sewage sludge site:

If the existing permit includes an accurate description, indicate so by checking yes on the application form. If no, provide this information only if authorization for the disposal of sewage sludge is being sought in the permit. If sewage sludge is disposed of at a site permitted or registered by another entity, it is not necessary to address ownership or the location description of the sewage sludge disposal site. If sewage sludge is generated and authorization for disposal is sought in the permit, provide a location description for the sewage sludge site. The location description must use easily identifiable landmarks found on the USGS map submitted as an attachment to the application. The description must include the distance in feet or miles from road intersections.

m. USGS Topographic Map

Provide a complete **original** full size USGS Topographic Quadrangle Map(s). These maps are in color and have a 7.5 minute scale. One source for the map is to call 1-888-275-8747. The USGS quadrangle maps must be in color, have a scale, have the latitude and longitude on all four sides of the map **and** contain all the information of the original USGS map.

One mile in all directions from the facility and any effluent or permitted sludge disposal sites must be shown on the map(s). If more than one map is required to show one mile in all directions from the facility, all USGS topographic maps must be full size and not spliced together. All applicable information below must be included on the USGS Map. On the map, the following must be clearly shown and clearly labeled:

- the applicant's property boundary
- the boundaries of the treatment plant
- the point of discharge

- the highlighted discharge route for a distance of three stream miles or until the effluent reaches a classified segment (only use a yellow or light colored highlighter, so that we may see the stream characteristics - do not mark over the discharge route with dark ink)
- the boundaries of the effluent disposal site such as the irrigation tract or subsurface drainfield
- all ponds including storage/evaporation/holding ponds
- the sewage sludge disposal site if it is in the existing permit or if the applicant is seeking authorization through a new/amended permit application
- all new and future commercial developments, housing developments, industrial sites, parks, schools, and recreational areas
- within one mile of the treatment facility, all springs, public water supply wells, monitor wells, surface water supply intakes, water treatment plants, potable water storage facilities, and sewage treatment facilities
- around the point of discharge and one mile downstream of the discharge route, all parks, playgrounds, and schoolyards must be highlighted and the name provided on the map

n. Discharge to Municipal, County, or State ditches:

Answer the question yes or no whether the treated effluent is discharged to a city, county, state highway right-of-way, or flood control district drainage ditch. Authorization from this entity must be obtained prior to commencing discharge. A permit does not grant this authorization. It must be authorized by the owner of the structure. If the answer to the question for this item is yes, please read the following and answer the remaining questions as appropriate.

For renewal application, indicate whether the entity granted authorization.

For new and amendment application, indicate by a check mark whether the entity granted authorization or if authorization is still pending. Provide a copy of the letter sent to the owner of the drainage structure with the application. Upon receipt, provide a copy of the response letter.

Indicate by a check mark that the owner of right-of-way or drainage ditch has been contacted and approved the discharge. If authorization is still pending, provide a copy of the proof of contact. If approved, provide approval letter.

o. Indian Land:

Indicate whether the facility is located on, or the discharge route passes through, Indian Land.

9. MISCELLANEOUS INFORMATION

a. Previous employment with the TCEQ

List each person formerly employed by the TCEQ who represented your company and was paid for service regarding the application. Any violation of the Health and Safety Code, Texas Water Code, or Government Code relating to conflict of interest may result in denial of the application or filing of charges with the appropriate office.

b/c Fee and Penalty information:

Please note that effective September 1, 2006, the TCEQ will no longer issue, amend, or renew permits, registrations, certifications, or licenses to an entity or person who is delinquent on a penalty or fee owed to the TCEQ. The TCEQ will not declare any application administratively complete that is submitted by a person or entity who is delinquent on a fee or penalty until the fee or penalty is paid, or if on an approved installment plan, that payments under the plan are current. The TCEQ will withhold final action on an application until the fee or penalty is paid and the account is current, if after the application is considered administratively complete, we discover that the owner or entity who submitted the application is delinquent on a fee or penalty.

Please identify whether you owe any fees or penalties to the TCEQ. If fees or penalties are owed, please identify the type of fee or penalty owed, the amount past due, and the TCEQ identifying number. For penalties, please provide the TCEQ docket number. For further information on the Delinquent Fee & Penalty Protocol, see the TCEQ web site at: www.tceq.state.tx.us/delin-protocol.

10. SIGNATURE PAGE**CERTIFICATION**

Each entity applying for the permit is required to sign the certification statement. The certification must bear an original signature of a person meeting the signatory requirements specified under 30 Texas Administrative Code (TAC) §305.44.

If you have any questions or need additional information concerning the signatory requirements discussed above, please contact the TCEQ's Environmental Law Division at 512/239-0600.

**30 Texas Administrative Code
§305.44. Signatories to Applications.**

(a) All applications shall be signed as follows.

(1) For a corporation, the application shall be signed by a responsible corporate officer. For purposes of this paragraph, a responsible corporate officer means a president, secretary, treasurer, or vice-president of the corporation in charge of a principal business function, or any other person who performs similar policy or decision-making functions for the corporation; or the manager of one or more manufacturing, production, or operating facilities employing more than 250 persons or having gross annual sales or expenditures exceeding \$25 million (in second-quarter 1980 dollars), if authority to sign documents has been assigned or delegated to the manager in accordance with corporate procedures. Corporate procedures governing authority to sign permit or post-closure order applications may provide for assignment or delegation to applicable corporate positions rather than to specific individuals.

(2) For a partnership or sole proprietorship, the application shall be signed by a general partner or the proprietor, respectively.

(3) For a municipality, state, federal, or other public agency, the application shall be signed by either a principal executive officer or a ranking elected official. For purposes of this paragraph, a principal executive officer of a federal agency includes the chief executive officer of the agency, or a senior executive officer having responsibility for the overall operations of a principal geographic unit of the agency (e.g., regional administrator of the EPA).

INSTRUCTIONS FOR DOMESTIC ADMINISTRATIVE REPORT 1.1

The following items are required only for new permit applications and major amendment applications; the following items are not required for renewal or minor amendment/modification applications.

1. AFFECTED LANDOWNER INFORMATION

- a. The following information is required for the affected landowners list and other interested parties. Please use the format described below. **Examples of landowners maps have been provided for review and assistance.** Affected landowner information is critical to the processing of the application and any errors may cause significant delays in the processing of the application. For facilities that fall on the border areas of Texas, you must identify all affected out-of-state landowners if they are adjacent to the facility, the disposal site, or the discharge route.

The landowners list is used by the TCEQ to notify affected landowners by mail of the application. These individuals, as well as others, can provide comments on the application or request a contested case hearing on the application.

- (1) All applicants must submit a map that clearly shows the following:
 - the applicant's property boundaries
 - the location of the treatment facility within the applicant's property
 - the property boundaries of landowners surrounding the applicant's property
 - the required buffer zone if the buffer zone requirement is not satisfied by ownership; see buffer zone requirements on Page 34 of the instructions or within 30 TAC Section 309.13(e)
- (2) For applications discharging wastewater to waters in the state, in addition to the landowners in item **a** above, the map must clearly show the following:
 - the point of discharge
 - the highlighted discharge route for one mile downstream from point of discharge
 - the property boundaries of all landowners surrounding the point of discharge and on both sides of the discharge route for one full stream mile downstream if the point of discharge
 - If the point of discharge is to a lake, bay estuary, or effected by tides, the delineate the property boundaries of landowners along the shoreline for a ½ mile radius from the point of discharge
- (3) For applications using land disposal of effluent, in addition to the landowners in item **a** above, the map must clearly show the following:
 - the property boundaries of the effluent disposal sites
 - all effluent holding/storage/evaporation ponds
 - the property boundaries of all landowners surrounding the disposal site.
- (4) For sewage sludge beneficial use land application site and/or incineration site; the map must clearly show the following:
 - the property boundaries of the beneficial use land application site and/or incineration site within the applicants property boundaries
 - the property boundaries of the landowners **surrounding** the applicant's property boundaries where the beneficial use land applications site and/or incineration site is located

- (5)** For sewage sludge disposal (monofill), the map must clearly show the following:
- the property boundaries of the sludge disposal site within the applicant’s boundaries.
 - the property boundaries of the landowners within ½ mile in all directions from the applicant’s property boundaries where the sewage sludge disposal site is located

If there are questions as to which landowners must be identified, call the Wastewater Permitting Section staff. The landowners map should be a city or county plat, another map sketch, or a drawing **with a scale** adequate enough to show the cross-referenced affected landowners. The landowners map must include a scale so that the TCEQ can verify that all landowners within the required distances have been identified.

Two examples of affected landowner maps have been provided as Example 5.

EXAMPLE 7(a)

Each type of affected landowner must be identified on the above maps. For example, in an application to increase flow, landowner from items **1** and **2** above must be shown. For increases in flow at a plant and disposal of wastewater via irrigation, landowners from items **1** and **3** above must be shown. If the application is for a new permit in which irrigation and beneficial land application of sewage sludge is being proposed, landowners from items **1**, **3** and **4** must be shown.

EXAMPLE 7(b)

This map shows all the landowners adjacent to the applicant’s property, surrounding the point of discharge, and all landowners along the discharge route for a distance of one mile downstream. In this map, landowners 1-10 must be identified as affected landowners with the landowner’s name and mailing address submitted with the application in the format described in item **1.b.** below.

- b.** In an effort to expedite processing of the application, the TCEQ requires applicants to provide the mailing list in one of the following formats. Either submit the mailing list electronically on a read/write Compact Disk (CD-RW) using Microsoft Word, as allowed by 30 TAC 39.5(b), or if more convenient, four sets of printed labels of the list may be provided in lieu of an electronic submission. One of these two methods of providing the affected landowners mailing addresses (electronically or printed labels) must be used. The application cannot be declared Administratively Complete until one of the two sets is received.

Please label the CD-RW with the applicant’s name and permit number. Within the file stored on the CD-RW, identify the permit number and applicant’s name on the top of the document. Names and addresses must be typed in the format indicated below according to U.S. Postal Service regulations for machine readability. Each letter in the name and address must be capitalized, contain no punctuation, and the appropriate two-character abbreviation must be used for the state. Each entity listed must be blocked and spaced consecutively as shown below.

EXAMPLE:

SHARMAN DUNN
RR 1 BOX 34
SEA TX 76724

MR AND MRS EDWARD PEABODY
1405 MONTAGUE LN
SEA TX 76710-1234

BRIAR LP
PO BOX 249
SEA TX 76710-0249

A list submitted electronically should be the only item on the CD-RW. Do not submit a list on CD-RW that includes maps or other materials submitted with your application.

If you choose to submit the mailing list in Microsoft Word format, it must be in Avery 5160 label format (3 columns across, 10 columns down, for a total of 30 labels per page).

If you provide the list on printed labels, please use sheets of labels containing 30 labels per page. Please provide four complete sets of labels of the adjacent landowners list.

Each name and corresponding address must appear only once on the mailing labels or CD-RW even if the entity owns more than one tract of land identified on the landowners map. Please eliminate duplicate names and addresses.

- c. All landowners identified must be clearly cross-referenced to a list of the landowner name's and complete mailing addresses. The cross reference must be in consecutive numeric order (1, 2, 3). The complete list of affected landowners must be provided on a **separate sheet of 8 ½" by 11" paper**. DO NOT USE PROPERTY TAX TRACT NUMBERING SYSTEM.
- d. Answer the question yes or no as to whether any permanent school fund land is affected by this application. This information is required by the Texas Water Code 5.115. If yes, provide the location of the property and foreseeable impacts and effects this application has on the land(s).

2. BUFFER ZONE REQUIREMENTS

The buffer zone map is used to show how the applicant will comply with the requirements of 30 TAC Section 309.13(e). This part of the regulations pertains to abating and controlling nuisance odor conditions from wastewater treatment plants. The buffer zone, either 150 or 500 feet from the treatment units (depending on the type of treatment unit) can be met by ownership, legal restrictions preventing residential structures within the buffer zone, an approved nuisance odor prevention plan, or a variance to the buffer zone. Ownership means that the applicant owns all the land surrounding the treatment units that fall within the buffer zone. The other three alternatives pertain to the portion of the buffer zone that is not owned by the applicant.

Legal restrictions are legal documents such as a deed recorded easement that prohibit residential structures within the part of the buffer zone that is not owned by the applicant. An approved nuisance odor prevention plan contains specific information and actions by the permittee to abate and control nuisance odor conditions. A variance to the buffer zone is an option that is considered on a case-by-case basis. A variance should only be requested when all other options to satisfy the buffer zone requirements have been explored and deemed infeasible. The applicant must provide proof during the application process that the other options are not feasible. The following is a portion of 30 TAC Section 309.13(e) which defines the buffer zone requirements:

- e. *One of the following alternatives must be met as a compliance requirement to abate and control nuisance of odor prior to construction of a new wastewater treatment plant unit, or substantial change in the function or use of an existing wastewater treatment unit:*

1. *Lagoons with zones of anaerobic activity (e.g., facultative lagoons, un-aerated equalization basins, etc.) may not be located closer than 500 feet to the nearest property line. All other wastewater treatment plant units may not be located closer than 150 feet to the nearest property line. Land used to treat primary effluent is considered a plant unit. Buffer zones for land used to dispose of treated effluent by irrigation shall be evaluated on a case -by-case basis. The permittee must hold legal title or have other sufficient property interest to a contiguous tract of land necessary to meet the distance requirements specified in this paragraph during the time effluent is disposed by irrigation;*
2. *The applicant must submit a nuisance odor prevention request for approval by the Executive Director. A request for nuisance odor prevention must be in the form of an engineering report, prepared and sealed by a licensed professional engineer in support of the request. At a minimum, the engineering report shall address existing climatological conditions such as the average direction and velocity of the prevailing winds (i.e., wind rose), surrounding land use which exists or which is anticipated in the future, wastewater characteristics in affected units pertaining to the area of the buffer zone, potential odor generating units, and proposed solutions to prevent nuisance conditions at the edge of the buffer zone and beyond.*

Proposed solutions shall be supported by actual test data or appropriate calculations. The request shall be submitted, prior to construction, either with a permit application and subject to review during the permitting process or submitted for executive director approval after the permitting process is completed: or,

3. *The permittee must submit sufficient evidence of legal restrictions prohibiting residential structures within the part of the buffer zone not owned by the applicant. Sufficient evidence of legal restriction may, among others, take the form of a suitable restrictive easement, right-of-way, covenant, deed restriction, deed recorded, or a private agreement provided as a certified copy of the original document. The request shall be submitted, prior to construction, either with a permit application and subject to review during the permitting process or submitted for Executive Director approval after the permitting process is completed.*
- f.** *For a facility for which a permit application, other than a renewal application, is made after October 8, 1990, if the facility will not meet the buffer zone requirements by one of the alternatives described in subsection (e) of this section, the applicant shall include in the application for the discharge permit a request for variance. A variance will be considered on a case-by-case basis and, if granted by the Commission, shall be included as a condition in the permit. This variance may be granted by the Commission, consistent with the policies set out in Texas Water Code,§26.003.*

*For the buffer zone requirements to be addressed in the application, the following information **must** be submitted with the application. An example map has been provided for review and assistance. The buffer zone map submitted as part of the application will become part of the permit if the applicant does not own the required buffer zone; therefore, please provide the buffer zone map on 8.5 by 11-inch paper. Therefore, it is very important that the map be accurate and clearly labeled.*

- a.** The buffer zone map must clearly show the following information: (Please label each item on the map)
- the applicant's property boundaries
 - each treatment unit and the distance in feet from each treatment unit to the applicant's property boundaries
 - the required buffer zone (500 feet for lagoons with zones of anaerobic activity, 150 feet for all other treatment units)
 - If the buffer zone is not owned by the applicant, the map must show the distance in feet the buffer zone extends into all surrounding property

An example of a buffer zone map has been provided as Example 8. This map shows the applicant's property boundaries, the treatment units (a package plant), the distance from the treatment units to the property boundaries, and the required buffer zone. In this scenario, the applicant does not own the required buffer zone. One of the three options discussed above must be chosen in order to satisfy the buffer zone requirements. A draft permit cannot be prepared until the buffer zone requirements are satisfied. Changing the method in which the buffer zone will be satisfied requires a major amendment to a permit.

- b.** Indicate by checking which requirement is being used to satisfy the buffer zone requirements
- c.** To answer the unsuitable site characteristics, review the following. If the site meets the requirements below, check yes. If one of the following is not met, check no. If no, the permit writer may contact the applicant so that additional information can be provided.

The treatment facility must also meet the requirement of 30 TAC 309.13(a) through (d). The unsuitable site characteristics, as defined in the rules are as follows:

A wastewater treatment plant unit may not be located in the 100-year flood plain unless the plant unit is protected from inundation and damage that may occur during that flood event.

A wastewater treatment plant unit may not be located in wetlands (This prohibition is not applicable to constructed wetlands.)

A wastewater treatment plant unit may not be located closer than 500 feet from a public water well as provided by 30 TAC Section 290.41 of this title (relating to Ground Water Sources and Development) nor 250 feet from a private water well. The following separation distances apply to any facility used for the storage, processing or disposal of domestic wastewater. Exceptions to these requirements will be considered at the request of a permit applicant on a case-by-case basis, and alternative provisions will be established in a permit if the alternative condition provides adequate protection to potable water sources and supplies.

A wastewater treatment plant unit, land where surface irrigation using wastewater effluent occurs, or soil absorption systems (including low pressure dosing systems, drip irrigation systems, and evapotranspiration beds) must be located a minimum horizontal distance of 150 feet from a private water well.

A wastewater treatment plant unit, or land where surface irrigation using wastewater effluent occurs, must be located a minimum horizontal distance of 500 feet from an elevated or ground potable-water storage tank as provided by 30 TAC Section 290.43 of this title (relating to Location of Clear Wells, Standpipes, and Ground Storage and Elevated Tanks.)

A wastewater treatment plant unit, or land where surface irrigation using wastewater effluent occurs, must be located a minimum horizontal distance of 500 feet from a public water well site as provided by 30 TAC Section 290.41 of this title, spring, or other similar sources of public drinking water.

A wet well or pump station at a wastewater treatment facility must be located a minimum horizontal distance of 300 feet from a public water well site, spring, or other similar sources of public drinking water as provided by 30 TAC Section 290.41 of this title.

A wastewater treatment plant unit, or land where surface irrigation using wastewater effluent occurs must be located a minimum horizontal distance of 500 feet from a surface water treatment plant as provided by 30 TAC Section 290.41 of this title.

A wastewater treatment facility surface impoundment may not be located in areas overlying the recharge zones of major or minor aquifers, as defined by the Texas Water Development Board, unless the aquifer is separated from the base of the containment structure by a minimum of three feet of material with a hydraulic conductivity toward the aquifer not greater than 10^{-7} cm/sec or a thicker interval of more permeable material which provides equivalent or greater retardation of pollutant migration. A synthetic membrane liner may be substituted with a minimum of 30 mils thickness and underground leak detection system with appropriate sampling points.

3. ORIGINAL PHOTOGRAPHS

At least one original photograph of each of the following must be submitted with the application:

- At least one photograph of the new and expanded treatment unit(s) location.
- At least one photograph of the existing/proposed point of discharge and as much area downstream as can be captured on film. If the discharge is to an open water body (e.g., lake, bay) the point of discharge should be in the middle of the photograph with as much area on both sides of the discharge as can be captured on film.
- At least one photograph of the existing/proposed effluent disposal site.

Submit a plot plan or map which indicates the location of each photograph and the direction (e.g., northwest) the camera was facing when the photograph was taken.

SUPPLEMENTAL PERMIT INFORMATION FORM (SPIF)

This form applies to TPDES permit applications.

The SPIF must be completed as a separate document. The TCEQ will mail a copy of the SPIF to each agency as required by the TCEQ Memorandum of Agreement with the EPA. If any of the items are not completely addressed and/or further information is needed, you will be contacted to provide the information before the permit is issued. Each item must be completely addressed.

When filling out the SPIF:

- **do not refer to a response of any item in the permit application form**
- Each attachment must be provided with this form, separately from the administrative report of the application

The application will not be declared administratively complete without this form being completed in its entirety including all attachments.

INSTRUCTIONS FOR DOMESTIC TECHNICAL REPORT 1.0

The following items are required for all permit applications - renewals, amendments and new permit applications. Please read the instructions carefully. Follow while completing the application.

Please provide detailed technical information as needed. If more than one outfall is included in the application, provide applicable information for each outfall. Please note that if an item does not apply to your facility, write N/A to indicate that you have considered it. Attach separate reports or additional sheets as needed. Cross-reference all attachments to the question in the Technical Report. You are not required to submit worksheets that do not apply to your application.

1. PERMITTED AND/OR PROPOSED FLOW

Provide the design flow rate of the treatment plant for the facility that is operational or which will be constructed within the next five years. Please note that if construction of facilities for specific phases will not be started within this five-year time period, then the phase may not be included in the proposed permit. This scenario is addressed in item 10 of Domestic Technical Report 1.0.

If the applicant is requesting an increase in the permitted flow, a major amendment to the permit is required.

2. NAICS and SIC CODE

Provide the Standard Industrial Classification Code (SIC) and the North American Industrial Classification System Code (NAICS) that best applies to the type of entities served by the facility. The following table includes typical SIC and NAICS codes for domestic wastewater permits. If none of the following NAICS and SIC Codes do not apply, provide the appropriate NAICS and SIC Code. Other NAICS Codes may be obtained from the North American Industrial Classification System manual, published in 1997. Additional SIC Codes are available from a variety of sources. For treatment facilities that provide wastewater service to a wide range of domestic, commercial, and/or industrial entities, SIC Code 4952 and NAICS Code 22132 may be most appropriate.

<u>SIC CODES</u>		<u>NAICS CODES</u>	
4941	Potable Treatment Plants	22131	Water Supply and Irrigation System
4952	Sewage Treatment Plants	22132	Sewage Treatment Facilities
5812	Eating Places	72211	Full-Service Restaurants
		722211	Limited-Service Restaurants
		722212	Cafeterias
		722213	Snack and Non-Alcoholic Beverage Bars
6515	Operators of Residential Mobile Home Site	53119	Lessors of Other Real Estate Property
7011	Hotels and Motels	72111	Hotels and Motels
		72112	Casino Hotels
		721191	Bed and Breakfast Inns
		721199	All Other Traveler Accommodations
7032	Sporting and Recreational Camps	721214	Recreation & Vacation Camps Except Campgrounds
7033	RV Parks and Campsites	721211	RV and Campgrounds
7996	Amusement Parks	71311	Amusement and Theme Parks
8051	Skilled Nursing Care Facilities	623311	Continuing Care Retirement center
8211	Elementary and Secondary Schools	61111	Elementary and Secondary Schools
8744	Private Correctional Establishments	56121	Facilities Support Services
9223	Governmental Correctional Institutions	92214	Correctional Institutions

3. TREATMENT UNITS

- a. Provide a detailed description of the treatment process. Describe the type of treatment system (i.e., activated sludge, pond system, trickling filter) and mode of operation (i.e., extended aeration mode, complete mix mode, conventional mode, pond system, etc.). Provide a detailed description tracing the flow of wastewater through the entire treatment process, starting with the headworks and finishing with the point of discharge. Include in the detailed description the sludge processing and drying units. Provide a separate description for each phase of the permit (i.e., interim and final).
- b. Provide the startup date of the current treatment facility. For example, if the facility was first built in 1990 for 0.10 MGD capacity, but the facility was expanded in July 1996 to accommodate a flow of 0.5 MGD, the answer to this question is July 1996.

Indicate whether Plans and Specifications have been submitted to the TCEQ for review and have been approved. Prior to the construction of the treatment units, the plans and specifications must be submitted to the TCEQ for review and approval. If the plans and specifications have been approved, provide the date approval was granted.

- c. For applicants with existing permits: check the Other Requirements page of the existing permit. If there is an Other Requirement that asks for the submission of a Summary Submittal Letter, please state if this has been resolved or not and any applicable dates. Include a copy of any approval letter from TCEQ.
- d. Indicate how the buffer zone requirements have been met. For a full explanation of buffer zone requirements please reference Page 22-23 of the instructions.
- e. For applicants with existing permits: check the Other Requirements page of the existing permit. If there is an Other Requirement that includes an action needed related to Buffer Zone requirements such as the submission of easements or a nuisance odor plan, please state what actions have been taken including dates.
- f. Attach flow diagrams for the existing facilities and/or each proposed phase of construction. The flow diagram must demonstrate the flow of wastewater through the plant from the headworks to the point of discharge (or disposal site) as well as the sludge processing sequence. Clearly show and label any on-site lift stations, bypass piping and constructed emergency overflows within the treatment system. An example flow diagram has been provided as Example 2.
- g. Provide the type and dimensions (length x width x height) of each treatment unit. A list of common processes or process modifications is provided as Example 1. A list of common treatment units is provided as Example 2.

4. POLLUTANT ANALYSIS OF TREATED EFFLUENT

Provide an analysis of the effluent discharge for all the listed constituents. Analyses are required for all existing facilities (including both discharge and land disposal of effluent). Please note that analyses for Dissolved Oxygen (DO) and Total Suspended Solids (TSS) are not required for facilities that dispose of effluent via land application. Electrical Conductivity is required only for facilities that dispose of effluent via irrigation. Facilities that discharge directly into the Houston Ship Channel, Segment Nos. 1006 and 1007, and facilities that discharge into salt water are required to provide an analysis for Enterococci. Facilities that discharge into fresh water are required to provide an analysis for *E. coli* bacteria. Facilities that land apply effluent should test for *E. coli* bacteria if the application is located in a fresh water watershed and Enterococci bacteria if the application is located in a salt water watershed. Facilities that discharge into 303(d) listed segments for bacteria and

or discharge into segments with a TMDL for bacteria are subject to bacteria limits based on bacteria rulemaking. For current information search the TCEQ public website: keywords bacteria rulemaking. Facilities with a design/permitted flow of one MGD or more are required to provide an analysis for Oil and Grease. Provide an analysis of the effluent for all the constituents, including those constituents that are not required to be monitored in the existing permit. Include the maximum sample analysis if more than one sample is taken. Provide the number of samples analyzed, the type of sample, whether grab or composite, and the date and time the sample(s) were collected.

Analytical data provided in the application must be sampled no later than one year prior to the date the application is submitted to the TCEQ. All sampling and laboratory testing methods should be performed according to 30 TAC Chapter 319, General Regulations Incorporated into Permits and 30 TAC Chapter 25, Environmental Testing Laboratory Accreditation and Certification. Collect DO in the early morning, before 9:00 a.m. Sample Chlorine Residual at the same time as *E coli* bacteria or Enterococci bacteria. If the sample for the other parameters is not obtained at the same time as the DO sample, provide the additional time of sampling. For pH, provide minimum and maximum values. Provide copies of the laboratory results sheet(s), QA/QC sheet(s), and chain-of-custody.

5. FACILITY OPERATOR

Provide the name, operator certification number, and class for the plant operator. If the operation of the plant is provided by an operations company, provide the name of the company and company's certificate number.

6. SEWAGE SLUDGE MANAGEMENT AND DISPOSAL

- a. Check all of the options that are currently utilized by the applicant to dispose of sewage sludge from this facility. If sewage sludge is transported to another wastewater treatment plant for further treatment, provide a written statement or a copy of contractual agreements confirming that the wastewater treatment plant identified above will accept and be responsible for the sludge from the plant for the life of the permit (at least five years). If such a statement or contact is not provided, authorization for such an activity cannot be included in a permit.
- b. Provide detailed information for **each** disposal site. The information must include the name of the site, the site's Permit or Registration Number, and the county in which the disposal site or sites are located.
- c. Provide the method used to haul the sludge to the disposal site. The hauler's Sludge Transporter Registration Number must also be provided, if applicable. Check whether the sludge is hauled in liquid, semi-liquid, semi-solid, or solid form. If the sewage sludge is land applied, check whether it is used for land reclamation or soil conditioning.

7. PERMIT AUTHORIZATION FOR SEWAGE SLUDGE DISPOSAL

- a. If the existing permit includes authorization for land application of sewage sludge for beneficial use and the applicant is requesting to continue this authorization, complete and submit the following application form: **APPLICATION FOR PERMIT FOR BENEFICIAL LAND USE OF SEWAGE SLUDGE (TCEQ Form No. 10451)** with this permit renewal application.

Note that the application requires a list of adjacent landowners, additional fees and other technical information concerning the land application of sewage sludge for beneficial use. For questions on completing this form, please contact the TCEQ Land Application Team of the Wastewater Permitting Section at 512/239-4671. Please note that adding a new authorization to the wastewater permit for beneficial land application of sewage sludge on

property located adjacent to the wastewater treatment facility requires a major amendment to the permit.

- b. If the existing permit includes authorization for the following sludge processing, storage or disposal options (Sludge Composting, Marketing and Distribution of sludge, Sludge Surface Disposal or Sludge Monofill or for temporary storage of sludge in sludge lagoons) and the applicant is requesting to continue this authorization, complete and submit the applicable portions of the following application form: **DOMESTIC WASTEWATER PERMIT APPLICATION: SEWAGE SLUDGE TECHNICAL REPORT (TCEQ Form No. 10056)**.

Please note that adding a new authorization for these sludge disposal options to a domestic permit requires a major amendment. Authorization for Composting of sewage sludge requires a major amendment to the permit if the composting operation has the potential to cause a degradation of water quality or the addition of treatment units which will encroach upon the buffer zone. Prior to submitting an application, contact the Municipal Permits Team for a determination of whether a major amendment is required.

8. SEWAGE SLUDGE SOLIDS MANAGEMENT PLAN

If the facility discharges into the Lake Houston Watershed, you must provide a solids management plan. The Lake Houston Watershed is defined in 30 TAC Section 311.31 as the entire drainage area of Lake Houston, with the exception of that portion of the drainage basin of the West Fork of the San Jacinto River that lies upstream of the Lake Conroe Dam. The Lake Houston Watershed includes all permit applications for facilities that discharge to Segment Numbers 1002, 1003, 1004, 1008, 1009, 1010, 1011, and 1015. A sample solids management plan is provided as Example 5 of these instructions.

If the facility accepts sludge from other domestic wastewater treatment facilities, you must provide a solids management plan that includes information concerning the treatment and disposal of the commingled sludge from the applicant's wastewater treatment plant and sludge from the other plant or plants. Indicate the permittee name, permit number and the amount of sludge accepted from other plants and the treatment and disposal process for the commingled sludge from the applicant's wastewater treatment facility and the sludge from the other plants.

The solids management plan should include the following:

- The dimensions (length x width x height) and capacities (gallons or cubic feet) of all sewage sludge handling and treatment units and processes.
- Calculations showing the amount of solids generated at design flow and at 75, 50 and 25 percent of design flow.
- Operating range for mixed liquor suspended solids in the treatment process based on the projected actual and design flow expected at the facility.
- A description of the procedure and method of solids removal from both the wastewater and sludge treatment processes.
- Quantity of solids to be removed from the process and schedule for removal of solids designed to maintain an appropriate solids inventory.
- Identification and ownership of the ultimate disposal site and a system of documenting the amount of solids disposed of in dry weight form.
- If the treatment system uses facultative lagoons, provide calculations describing the design life of the sludge holding volume in the ponds. Provide the location and depth of any monitoring wells located in the area of, and adjacent to, the facultative lagoons. Describe how the sludge will ultimately be disposed of upon reaching the design life of the facultative lagoons and other ponds, if utilized.

9. SEWAGE SLUDGE LAGOONS

1. Location information

- a. The following are descriptions of the maps required and the information that must be shown on the maps. Indicate with check marks on the application form that the maps and associated information has been provided.

Submit one **ORIGINAL General Highway (County) Map** showing the location of the sludge lagoons with a scale sufficient to show the distance of the disposal area from the property line in accordance with 30 TAC Section 312.63 and all areas within 1000 feet of the site. Mark in red ink the applicant's property boundaries and the sludge lagoons location. (Copies may be submitted on 8.5 x 11-inch sheets). For County Highway Maps, you may call the Texas Department of Transportation Map Sales in Austin.

Submit a legible copy of a **USDA Natural Resources Conservation Service (NRCS) Soil Map** with soil legend and necessary interpretative information. Contact the nearest NRCS office for map information. If county is not mapped, have a soil scientist identify the soils.

Submit a copy of the **Federal Emergency Management Agency (FEMA) Map** showing the 100-year flood plain. These maps can be obtained by requesting a Flood Insurance Study (no charge) from the FEMA Flood Map Distribution Center at (800) 358-9616. The Flood Insurance Study will contain a booklet and the FEMA maps.

- b. The information requested in this item is self-explanatory. It includes checking the appropriate spaces if the sludge lagoon(s) contains certain features, and a description of protective measures to be utilized to protect the sludge lagoons from a 100-year frequency flood, if a portion of the sludge lagoons lies within the flood plain.

2. Temporary Storage Information

Digested sludge may be stored in the sludge lagoon(s) for a period not to exceed two years unless otherwise authorized by the Executive Director. Digested sludge may be stored in the sludge lagoon(s) for a period not to exceed five years if the person who prepares the sludge demonstrates that the land on which the sewage sludge remains is not an active sludge unit or surface disposal site pursuant to 30 TAC Section 312.61(c). The demonstration shall include the following information, which shall be reviewed by the Executive Director and retained by the person who prepares the sewage sludge for the period that the sewage sludge remains on the land: an explanation of why sewage sludge needs to remain on the land for longer than two years prior to final use or disposal; the date by which the sewage sludge will be used or disposed. This date must clearly maintain a storage period less than five years. The final disposal of the sludge at the plant site is a violation of this permit. Sludge placed in sludge lagoon(s) is for temporary storage only. Sludge must ultimately be disposed of in accordance with the closure plan.

- a. An analysis of the following pollutants in milligrams per kilogram (mg/kg) must be submitted with the application:

Arsenic	Lead	Selenium	Nitrate Nitrogen	pH, Standard Units
Cadmium	Mercury	Zinc	Total Nitrogen	
Chromium	Molybdenum	Total PCB's	Phosphorus	
Copper	Nickel	Ammonia Nitrogen	Potassium	

The latest analysis performed on the sludge (i.e. TCLP toxicity, priority pollutants) should be submitted with the application. Analytical procedures for sludge testing shall be in accordance with the extraction methods specified in Standard Methods for the Examination of Water and Wastewater and American Society of Agronomy's Methods of Soil Analysis. Sludge test results shall be reported on a dry weight basis.

b. The information requested in this item is self-explanatory.

3. Facility information

Please note that depending on the yes/no response, additional descriptive information may be required.

4. Site development plan

a. Describe the methods used to deposit sludge in the sludge lagoon(s). This description should include site layout plan, site entrance roads from public access roads, rate of sludge deposition, average lift size, maximum lift, average trench or cell size, maximum cell or trench size, protection from floods, and other information necessary to depict how the surface disposal unit will be developed.

b. Indicate with check marks that the following information has been provided.

- A plan view and cross-section of the sludge lagoon(s)
- A copy of any closure plan that has been developed for the sludge lagoon(s)
- Size of the sludge lagoon(s) in surface acres and capacity in cubic feet and gallons.
- Description of the method of controlling infiltration of ground and surface water from entering site.
- Description of procedures to be used to prevent the occurrence of nuisance conditions

5. Groundwater monitoring

Please note that depending on the response, additional descriptive information may be required or monitoring wells may be required in the permit.

10. REQUIREMENTS/COMPLIANCE/ENFORCEMENT

a. Indicate if the permittee has any additional authorizations that pertain to pollution control activities conducted at this facility (site), such as a 30 TAC Chapter 210 reuse authorization, a separate sludge processing or sludge land application permit, etc. If yes, provide the TCEQ authorization number and description of the authorization:

b. Answer yes or no whether the applicant is currently required to meet any implementation schedule for the construction, operation, or upgrading of the wastewater treatment facility. If yes, provide a background discussion of the requirements of the implementation schedule and a progress report in satisfying the schedule. This requirement includes Federal, State, or local authority permit conditions, administrative or enforcement orders, enforcement compliance schedule letters, stipulations, court orders, or grant and loan conditions.

11. UNBUILT PHASES

Indicate whether the existing permit contains phases that have not been constructed within five years of permit issuance. For example, the existing permit authorizes flows of 0.10 MGD and 0.20 MGD; the facility is currently operating in the 0.10 MGD phase and the 0.2 MGD phase was authorized seven years ago. In this situation, the answer to the question is yes. If yes, the remainder of the questions must be answered and the information provided.

If the permit contains a phase that has not been constructed or in operation, provide a detailed discussion regarding the continued need for the unbuilt phase. The commission is charged with the responsibility of determining the need for a permit. For unbuilt phases, provide an anticipated construction and operation schedule for each phase. If construction is dependent upon housing/commercial development, provide information from the developer for the scheduled start dates for development phases. Attach this schedule to the application. Failure to provide sufficient justification for the continued need for the permit and/or each identified phase may result in a recommendation for denial of the application or removal of unbuilt phases from the permit. The deletion on an unbuilt phase does not preclude a permittee for applying for a major amendment to increase flow in the future. However, in implementing regionalization, the permittee will be required to provide additional information to justify the increase in flow.

12. SITE DRAWING

Provide a site drawing on an 8.5-inch by 11-inch sheet of paper that shows the boundaries of the treatment facility and the area served by the treatment facility. In addition, provide the name and description of the area served by the treatment facility. For facilities that dispose of effluent via land application (irrigation, subsurface disposal, evaporation, etc.), show the location of all effluent storage/holding ponds evaporation ponds and the disposal area. Indicate the general slope of the land. For facilities that include authorization to dispose of sludge by beneficial land application or surface disposal, show the location of the sludge application site or the disposal site. If this information can be shown on the USGS map submitted in response to Item 5 of the Administrative Report 1.0. The USGS map is acceptable so long as it is copied to an 8.5-inch by 11-inch sheet of paper.

13. RCRA/CERCLA/OTHER WASTES

- a.** Answer yes or no whether the facility receives, will receive, or has received in the past three years Resource Conservation Recovery Act (RCRA) hazardous wastes by truck, rail, or dedicated pipeline.
- b.** Answer yes or no whether the facility received, will receive, or has received in the past three years Comprehensive Environmental Response, Compensation, and Liability Act (CERCLA) wastewater, RCRA remediation/corrective action wastewater, and/or other remedial activity wastewater.
- c.** If yes to either items a. or b., a detailed attachment to the application must be provided. The attachment should include the origin of the waste(s), a description of the waste(s) including the Hazardous Waste Number, quantity, and concentration, any waste treatment(s) prior to the waste(s) being accepted at the treatment facility, frequency of acceptance at the treatment facility, and the method(s) of transportation to the treatment facility (e.g., pipeline, railcar, truck, etc.).

INSTRUCTIONS FOR DOMESTIC TECHNICAL REPORT 1.1 - NEW AND AMENDMENT

The following items are required only for new permit applications and amendment applications; the following items are not required for renewal applications.

1. PERMITTED AND/OR PROPOSED FLOWS

- a.** Provide the design flow rate that is currently permitted (initial/existing for amendments) and/or design flow rates being requested that will be constructed within the next five years. For example, if a new permit is being sought and two phases are requested (0.1 and 0.2 MGD), fill in 0.1 in the initial/existing box and 0.2 in the final phase box. If the applicant is seeking to increase flow from 0.1 (currently permitted flow) to 0.2 MGD, fill out 0.1 in the initial/existing box and 0.2 in the final phase box. Please note that if construction of facilities for specific phases will not be started within this five-year time period, then the phase may not be included in the proposed permit.

Prior to submitting a TPDES permit application, the applicant must determine if the receiving water is listed on the State of Texas Clean Water Act Section 303(d) list. This list identifies waters in the state that do not meet, or are not expected to meet, applicable water quality standards. If the receiving water is on the 303(d) list, the TCEQ will carefully evaluate if the proposed new permit or proposed additional discharge (e.g., flow increase) will cause or contribute to the violation of water quality standards. Requirements found at 40 CFR 122.4(i) prohibit any issuance of a permit to a new source or a new discharger if the discharge will cause or contribute to a violation of water quality standards.

- b.** Provide **JUSTIFICATION** for the flows proposed by the applicant. The Commission is charged with the responsibility of determining the need for a permit. Provide an anticipated construction start date and operation schedule for each phase being proposed. If construction is dependent upon housing/commercial development, provide information from the developer. Provide information such as the size of the development (number of lots), the date construction on the development is scheduled to begin, and the anticipated growth rate of the development (number of houses per month or year). Failure to provide sufficient justification for the continued need for the permit and/or each proposed phase may result in a recommendation for denial of the application or proposed phases. If additional space is needed, submit the justification information as an attachment.

Attach population estimates and/or projections used to derive the flow estimates and anticipated growth rates for developments. Provide the source and basis upon which population figures were derived (i.e., census and/or other methodology). Also, provide population projections at the end of the design life of the treatment facility and the source and basis upon which population figures were derived.

- c.** The TCEQ is required to implement the state policy to encourage and promote the development and use of regional and area-wide waste collection, treatment and disposal systems to serve the disposal needs of the citizens of the state and to prevent pollution and maintain and enhance the quality of the water in the state.

- 1.** If the applicant is a city, this item does not apply. Indicate if any portion of the proposed service area is located in an incorporated city. If yes, provide the name of the city and provide correspondence from the city concerning service for the proposed

wastewater treatment plant (consent to provide service or denial to provide service from the city). If consent to provide service is available from the city, provide justification for the proposed facility and a cost analysis of expenditures that shows the cost of connecting to the city versus the cost of the proposed facility or expansion.

2. Indicate if any portion of the proposed service area is inside another utility's CCN area. To obtain information concerning regional providers with sewer CCNs (Certificates of Convenience and Necessity), contact the TCEQ Utilities and Districts Section at 512/239-4691 or by fax at 512/239-6972. If yes, then provide justification for the proposed facility and a cost analysis of expenditures that shows the cost of connecting to the CCN facilities versus the cost of the proposed facility or expansion.
3. If there are any permitted domestic wastewater treatment facilities or sanitary sewer collection systems located within a three-mile radius of the proposed wastewater treatment facility, provide a list of all of these facilities, including the permittee's name and wastewater permit number. Identify and indicate these facilities on an area map. To obtain a map with the location of domestic wastewater permits located within a three-mile radius of the proposed facility, contact the TCEQ Information Services staff at 512/239-DATA. Provide copies of your certified letters to these facilities and response letters from these facilities concerning wastewater service for the proposed service area. If any of these facilities agree to provide service, provide justification for the proposed facility and a cost analysis of expenditures that shows the cost of connecting to these facilities versus the cost of the proposed facility or expansion.

2. PROPOSED ORGANIC LOADING

- a. Answer the question yes or no whether the application is for a new permit. If yes, skip to item c. If no, answer item b.
- b. Provide the Total Average Flow, the Average Organic Strength of the influent to the treatment plant, and the Average Loading in pounds per day at the treatment plant for design purposes. **This item is only required for amendment applications.** The Total Average Flow is the design flow of the facility. The average influent strength is from actual influent measurements taken over the past 12 months and is representative of the influent to the treatment facility. If the influent strength will be impacted by the amendment, the table in item 13.a. must be completed showing the source, flow and strength of the new source(s). For example, if the permit is being revised to accept large flows from a meat processing facility, the increase flow will likely increase the BOD strength received at the facility and impact the ability of the plant to consistently meet the permitted effluent limitations.

If the influent BOD₅ concentration is less than 200 mg/l and the proposed design calculations use an influent strength of less than 200 mg/l BOD₅, provide supporting influent BOD₅ data for a minimum period of 12 months that consistently show a lesser influent wastewater strength. The data should be based on 24-hour flow weighted composite samples taken a minimum of once per week for the duration of the study and include the BOD₅, flow, day and time sample was taken. The samples must be taken on different days of the week to be considered representative samples. Be advised that a permit may contain a provision requiring monitoring of the influent at regular intervals to verify that the influent strength has not increased. A permit may also contain an influent loading limitation if the design calculations use an influent strength of less than 200 mg/l BOD₅.

- c. Provide a breakdown of the sources of influent contributions, the total average flows, and organic strengths for each proposed phase for design purposes. Provide the Total Average Flow, the Average Organic Strength of the influent to the treatment plant, and the Average Loading in pounds per day at the treatment plant. The average BOD₅ should be calculated on a flow-weighted average basis. **This item is only required for new applications.**

3. PROPOSED EFFLUENT QUALITY AND PROPOSED DISINFECTION

For each phase, provide the proposed effluent quality, based on a 30-day average, for the listed constituents. Indicate the type of disinfection for each phase. Indicate the type of dechlorination process for each phase, if applicable. Please be advised that an 85 percent reduction for BOD₅ and TSS, based in influent versus effluent quality, must be achieved per the Clean Water Act.

4. DESIGN CALCULATIONS

Provide detailed design calculations that show the ability of the treatment system to meet the proposed effluent quality for each phase, according to the requirements of 30 TAC Chapter 217, Design Criteria for Sewerage Systems.

In addition, according to Chapter 217, describe design features (auxiliary power, alarm systems, standby and duplicate units, holding tanks, storm water clarifiers, etc.) and functional arrangements (flexibility of piping and of valves to control flow through the plant, reliability of power source, etc.) to prevent bypassing or overflows of untreated wastewater that might result from: (A) excessive inflow or infiltration, (B) power failure, (C) equipment malfunction, (D) plant unit maintenance and repair, or (E) any other. Each one of the above situations, (A) to (E), must be addressed. If the facility does not include a design feature or functional arrangement to address each one, state this in the design calculations. An example of design criteria and features has been provided as Example 4.

5. FACILITY SITE

- a. Provide the information required concerning flood protection and wetlands. Treatment units must be protected from inundation from a 100-year frequency flood event. It is the responsibility of the applicant to contact the U.S. Army Corps of Engineers to obtain all necessary authorization, including a Federal Clean Water Act Chapter 404 Dredge and Fill permit.
- b. Submit a wind rose that indicates the direction of the prevailing winds. Wind roses can be obtained by contacting the National Climatic Data Center at (828) 271-4800 or by visiting <http://www.ncdc.noaa.gov/oa/ncdc.html>

6. AUTHORIZATION FOR SEWAGE SLUDGE DISPOSAL

- a. If the applicant is requesting authorization to land apply sewage sludge for beneficial use on property located adjacent to the wastewater treatment plant, the applicant must complete and submit the following application form: **APPLICATION FOR PERMIT FOR BENEFICIAL LAND USE OF SEWAGE SLUDGE (TCEQ Form No. 10451)** with this permit application. Note that the application requires a list of adjacent landowners, additional fees and other technical information concerning the land application of sewage sludge for beneficial use. For questions on completing this form, please contact the TCEQ Land Application Team of the Wastewater Permitting Section at 512/239-4671.

- b.** If the applicant is requesting authorization for any of the following sludge processing, storage or disposal options (Sludge Composting, Marketing and Distribution of sludge, Sludge Surface Disposal or Sludge Monofill or for temporary storage of sludge in sludge lagoons) in this permit, the applicant must complete and submit the applicable portions of the following application form: **DOMESTIC WASTEWATER PERMIT APPLICATION: SEWAGE SLUDGE TECHNICAL REPORT (TCEQ Form No. 10056)**.

7. SEWAGE SLUDGE SOLIDS MANAGEMENT PLAN

If this application is for a new permit or for a major amendment to a permit, you must submit a sewage sludge solids management plan. The solids management plan should include the following:

- a.** The dimensions (length x width x height) and capacities (gallons or cubic feet) of all sewage sludge handling and treatment units and processes.
- b.** Calculations showing the amount of solids generated at design flow and at 75 percent, 50 percent and 25 percent of design flow.
- c.** Operating range for mixed liquor suspended solids in the treatment process based on the projected actual and design flow expected at the facility.
- d.** A description of the procedure and method of solids removal from both the wastewater and sludge treatment processes.
- e.** Quantity of solids to be removed from the process and schedule for removal of solids designed to maintain an appropriate solids inventory.
- f.** Identification and ownership of the ultimate disposal site and a system of documenting the amount of solids disposed of in dry weight form.
- g.** If the treatment system uses facultative lagoons, provide calculations describing the design life of the sludge holding volume in the ponds. Provide the location and depth of any monitoring wells located in the area of, and adjacent to, the facultative lagoons. Describe how the sludge will ultimately be disposed of upon reaching the design life of the facultative lagoons and other ponds, if utilized. An example of a sewage sludge solids management plan has been provided as Example 4.

WORKSHEETS FOR THE DOMESTIC TECHNICAL REPORT

The following worksheets may be required to be completed and submitted with the permit application. Depending on the method of disposal, authorizations being sought, or the permitted flow from the facility, some of the following worksheets must be submitted as part of the application.

DOMESTIC WORKSHEET 2.0: RECEIVING WATERS

If the application includes the discharge of treated effluent directly to surface waters in the state (i.e., to Doe Creek, or to an unnamed tributary), complete and submit this worksheet.

DOMESTIC WORKSHEET 2.1: STREAM PHYSICAL CHARACTERISTICS

If the application is for a new permit, an amendment application seeking to add an outfall, or is a renewal or amendment application for a permit with an existing or proposed phase of 1.0 MGD or greater, complete and submit this worksheet.

DOMESTIC WORKSHEET 3.0: LAND DISPOSAL OF EFFLUENT

If the application includes the disposal of treated effluent via land disposal (irrigation, subsurface disposal, evaporation, etc.), complete and submit this worksheet. For renewal applications that are not seeking to change anything at the effluent disposal site, complete and submit this worksheet.

DOMESTIC WORKSHEET 3.1: LAND DISPOSAL OF EFFLUENT - NEW AND AMENDMENT

For new permit applications or amendment applications (i.e., add land disposal, increase acreage, change locations, increase application rate). If the application is for a new permit or an amendment, this worksheet must be submitted. For example, to increase an application rate or increase the size of the irrigation site requires an amendment.

DOMESTIC WORKSHEET 3.2: SUBSURFACE IRRIGATION SYSTEMS (NON-DRIP SYSTEMS)

If land disposal method is by a subsurface land application non-drip system (conventional drainfield, pressure dosing, mound system, etc), complete and submit this worksheet.

DOMESTIC WORKSHEET 3.3: SUBSURFACE AREA DRIP SYSTEMS

If land disposal method is by a subsurface area drip system, complete and submit this worksheet. Please submit 1 original and 4 copies of the application. NOTE: All applicant's authorized or proposing subsurface disposal MUST complete and submit Worksheet 9.0.

DOMESTIC WORKSHEET 4.0: POLLUTANT ANALYSES REQUIREMENTS

If the application includes the following, complete and submit this attachment:

- an existing facility with a design/permitted flow of 1.0 MGD or greater
- a facility, with multiple permit phases, that includes an authorized or proposed phase at a design flow of 1.0 MGD or greater
- the applicant is a POTW that has or is required to have an approval pretreatment program; unless the facility is a minor (less than 1.0 MGD) **AND** the applicant has submitted certification to the Storm Water & Pretreatment Team that the facility does not have SIUs

DOMESTIC WORKSHEET 5.0: TOXICITY TESTING REQUIREMENTS

If the application includes the following, complete and submit this attachment:

- facilities with a currently-operating design flow greater than or equal to 1.0 MGD;
- applicants with an EPA-approved pretreatment program (or those that are required to have one under 40 CFR Part 403); unless the facility is a minor (less than 1.0 MGD) **AND** the applicant has submitted certification to the Storm Water & Pretreatment Team that the facility does not have SIUs or
- other facilities required by the TCEQ to perform Whole Effluent Toxicity testing.

Outfalls where routine toxicity testing is being conducted as a requirement of the current permit do not need to retest or submit test results.

DOMESTIC WORKSHEET 6.0: INDUSTRIAL WASTE CONTRIBUTION

If the applicant is a Publicly Owned Treatment Works (POTW) complete and submit this worksheet. Note that privately-owned facilities **do not** need to submit this worksheet with the technical report.

DOMESTIC WORKSHEET 7.0: CLASS V INJECTION WELL INVENTORY/ AUTHORIZATION

If the applicant is proposing new, amended or renewal of disposal of treated effluent via subsurface disposal, complete and submit this worksheet to the address specified in the worksheet.

INSTRUCTIONS FOR DOMESTIC WORKSHEET 2.0 - RECEIVING WATERS

All applicants submitting a renewal, amendment, or new permit for tpdes permits, must complete worksheet 2.0. Applications for a permit to dispose of all wastewater by land disposal are not required to complete this attachment.

All applicants must submit USGS quadrangle maps showing the location of the facility and the discharge point(s) and/or the land treatment/land application area, as appropriate. If this is an application for a discharge permit, USGS quadrangle maps must be submitted that depict the discharge route for three miles from the point of discharge or until a classified segment is reached as defined in 30 TAC Chapter 307, Appendix C, Texas Surface Water Quality Standards, whichever is first. The map(s) submitted as part of the Administrative Report 1.0 can be used for this worksheet. The permittee should retain a copy of the information for reference in subsequent applications.

If the facility has, or is proposing multiple points of discharge (outfalls) and the outfalls do not enter the same receiving water, attach additional sheets for each outfall. The outfalls that flow into each receiving water should be listed.

1. DOMESTIC DRINKING WATER SUPPLY

Answer the question yes or no whether a surface water intake for domestic drinking water supply is located within 5 miles downstream of the existing/proposed outfall(s). If yes, identify and label any surface water intake for domestic drinking water supply located within five miles downstream from the point/proposed point of discharge. Accurately locate and label the intake point for the drinking water supply on the USGS 7.5-minute topographic map.

2. DISCHARGE INTO TIDALLY AFFECTED WATER

Items **a.**, **b.**, and **c.** are yes/no questions. The information is specific to each point of discharge. If discharging to tidally affected waters, indicate the width of the receiving water at the outfall. If oyster reefs and/or Sea Grasses are located in the vicinity of the discharge, provide the distance and direction from the outfall.

3. CLASSIFIED SEGMENT

Indicate if the discharge is directly into (or within 300 feet of) a classified segment as defined in Appendix C or a partially classified waterbody as defined in Appendix D of the Texas Surface Water Quality Standards (30 TAC Section 307.10). The Water Quality Standards Team of the Water Quality Assessment Section can be contacted to determine if the receiving water is a classified segment.

If Yes, stop here. You do not need to complete Items 4 and 5. It is not necessary to complete Worksheet 2.1 - Stream Physical Characteristics Worksheet.

If No, and the discharge goes into a watercourse such as a creek, ditch, or series of tributaries prior to flowing into a classified segment, then complete Items 4 and 5.

4. DESCRIPTION OF RECEIVING WATERS

- a.** These items refer to the immediate receiving water (at the point the treated effluent is discharged). Check the item which best describes the first receiving water into which the discharge will flow after it leaves the outfall.
- b.** If a man-made channel, ditch, or stream was checked in item **4.a**, answer item **4.b**. Check only one of the characteristics that best describes and characterizes the area **upstream** of the discharge point for existing dischargers. For new permit application, check only one of the characteristics that best describes and characterizes the area **downstream** of the proposed discharge. Check the method used to determine the characteristic for describing the area upstream or downstream.
- c.** List the names of all perennial streams that join the receiving water (discharge route) within three miles downstream of the existing or proposed point of discharge.
- d.** Answer yes or no whether the receiving water characteristics change within three miles downstream of the point of discharge. If yes, provide a discussion of how the characteristics change.
- e.** Provide general observations of the water body during normal dry weather conditions.

5. GENERAL CHARACTERISTICS OF WATER BODY

- a. Indicate** by checking one or more activities that influence the area upstream of the existing or proposed point of discharge into which the treated effluent will flow after it leaves the outfall. These items refer to the immediate receiving water (e.g., a drainage ditch, a stream, a lake, a bay, etc.).
- b. Indicate** by checking one or more uses of the waterbody, either observed or evidences of uses. If the waterbody has a use that is not listed, check “other” and describe the use in the space provided.
- c. Check** one of the descriptions provided to best describe the aesthetics of the receiving water and surrounding area.

INSTRUCTIONS FOR DOMESTIC WORKSHEET 2.1 STREAM PHYSICAL CHARACTERISTICS WORKSHEET

DOMESTIC WORKSHEET 2.1 IS REQUIRED FOR THE FOLLOWING PERMIT APPLICATIONS:

1. New permit applications;
2. All (new, amendment or renewal) permit applications that include an existing or proposed phase to discharge 1.0 MGD or greater; and,
3. Amendment permit applications requesting to add a new outfall.

Worksheet 2.1 is not applicable for renewal or amendment permit applications that authorize the discharge of less than 1.0 MGD unless the amendment requests to add a new outfall.

Note that Worksheet 2.1 applies only to perennial streams and intermittent streams with persistent (perennial) pools as identified in Worksheet 2.0, item 4.b. If the discharge is directly to a classified segment as defined in Appendix C or to a partially classified water body as defined in Appendix D of the Texas Surface Water Quality Standards (30 TAC Section 307.10), then it is not necessary to complete Worksheet 2.1. If the information required in this section has been provided in a previous application, please resubmit the information. If the discharge is to an intermittent stream, Worksheet 2.1 is not required.

Questions on conducting a stream assessment or completing this worksheet should be directed to the Water Quality Standards Team of the Water Quality Assessment Section.

1. DATA COLLECTION

CONDUCT THE PHYSICAL ASSESSMENT DOWNSTREAM OF THE PROPOSED OR EXISTING OUTFALL.

Summarize the measurements in Item 2. The worksheet is divided into two portions. The upper portion of item 1 is for general information, and general observations made over the entire reach, while the lower or boxed portions are for measurements and observations made at specific transect locations.

Transect measurements are usually made beginning at the point of discharge (outfall) and continuing downstream. Once these are completed, general observations are made over the reach while returning to the point of discharge.

Observe or measure stream widths with a minimum of four and a maximum of ten equally spaced locations over a 0.5 mile reach. The number of transects depends upon width variability. At each point where width measurements are made, also measure the water depth at 4-10 points across the transect. Include transects within each habitat type (pool, riffle, run, glide) if they exist. If pools are present, include measurements across the deepest area. Show the location of the transects on the USGS map and the proposed point of discharge.

Characterize each transect site as riffle, run, glide or pool. For a definition of each, see the Definitions section of the instructions.

2. SUMMARIZE MEASUREMENTS

After finishing the transect measurements, complete the general observation portion of the worksheet. Count the number of stream bends and determine their definition (well, moderate, poor - see Definitions section). Count the number of riffles and estimate the magnitude of flow fluctuations. Look for evidence of debris in bank trees or its position on stream banks (upper, middle, lower). Another indication of flow fluctuations is how well

stream flow covers the channel. If water has receded from banks exposing bottom substrates, fluctuations may be severe. The best source of evidence is historical USGS stream flow records, if available. Indicate observed channel obstructions (fences, log jams, culverts, low water bridges, etc.) and channel modifications (channelized, cleared, leveed, concrete lined, rip-rapping, etc.).

At an appropriate location within the stream reach, measure stream flow. **IT IS VERY IMPORTANT TO IDENTIFY THE FLOW MEASUREMENT METHOD.**

INSTRUCTIONS FOR DOMESTIC WORKSHEET 3.0 LAND APPLICATION OF EFFLUENT

Worksheet 3.0 is required for renewal, amendment and renewal applications if you are currently authorized or requesting new or amended authorization to use land application as a method of disposal for treated effluent. Example 10 is a water balance and storage calculation.

Complete this attachment if you are **1)** currently authorized in your existing permit to utilize land application of your effluent **AND 2)** this permit application is **NOT** requesting changes from your existing permit conditions. Complete Worksheets 3.0 **AND** 3.1, 3.2, or 3.3 for new, renewal, and amendment permit applications requesting land disposal.

1. TYPE OF APPLICATION SYSTEM

Indicate by checking the type of existing/proposed system utilized for land disposal of treated effluent. If the method utilized is not listed, check "Other" and describe in detail the existing/proposed disposal system. All applications proposing new, amended or renewal of subsurface disposal **MUST** complete and submit Worksheet 7.0. Submit this worksheet separately to the address shown on the upper left corner of Worksheet 7.0.

2. LAND APPLICATION AREA

Fill in each box with the appropriate information. Provide the amount of effluent for irrigation/land disposal in gallons per day. Provide the number of acres for each crop to be irrigated. Describe the land use (i.e., golf course, landscape, pastureland, agricultural land) and the type of crops (Bermuda grass, alfalfa, cotton, native vegetation). If the crops irrigated differ, provide the number of acres for each crop and the growing seasons. Also indicate if the irrigation/land disposal site is/will have public access. Public access is not limited to the general public.

3. STORAGE AND EVAPORATION PONDS

Provide information on the storage and/or evaporation ponds. Indicate the number and size of the storage/holding ponds used to store treated effluent prior to irrigation/land application or the evaporation ponds. Provide the surface area in acres and the storage capacity in acre-feet of each effluent storage/holding pond. (A minimum of 2 feet of freeboard is required for each pond.) Describe the type of storage/holding pond liner (e.g., compacted clay, synthetic liner, other).

Provide documentation completed by a Texas licensed professional engineer that the liner meets the requirements of 30 TAC Chapters 309 and 217.

4. FLOOD AND RUNON PROTECTION

Answer yes or no whether the existing/proposed disposal site is located within the 100-year frequency flood level. List the source(s) used to determine the 100-year frequency flood plain. Describe how rainfall runon will be controlled such that extraneous water does not enter the land application site and all the tailwater control facilities and operations.

5. ANNUAL CROPPING PLAN

Submit an annual cropping plan that includes but is not limited to the following items:

- a. A soils map depicting the location of the crops proposed or currently being grown. These locations should be identified by field and crop on the soils map.
- b. All types of crops and acreage irrigated for each crop, including a warm and cool season crop.
- c. Growing seasons for each crop including months the field is left fallow (no crops).
- d. Nutrient requirements for each crop.
- e. Provide the minimum and maximum harvest height for the crop (e.g. mowing height of grasses).
- f. Supplemental watering requirements for each crop.
- g. Salt tolerances of each crop.
- h. Describe the harvesting method and the proposed number of harvests for each crop.
- i. Additional fertilizer requirements for each crop, proposed additional fertilizer applications for each crop, and methods of fertilizer application for each crop, based on annual soil sampling and analysis.
- j. If the proposed crop is existing native vegetation that will not be harvested, include a justification that the non-removal of crops will not lead to a buildup in nutrients.

6. WELL AND MAP INFORMATION

Indicate the exact boundaries of the land application operation on the original USGS topographic map (7.5-minute scale) of the area. Indicate on the original USGS topographic map (7.5-minute scale) all land that is to be a part of the disposal operation in addition to the following: on-site buildings; waste disposal or treatment facilities; effluent storage and tail water control facilities; buffer zones. Indicate on the original USGS topographic map all water wells located within a one-mile radius of disposal site or property boundaries. Provide a scale drawing to show details of the above items. Indicate on the original USGS topographic map all springs, seeps, and surface waters in the state located on the site and within 500 feet of the property boundaries.

Fill in the table with all of the information for all of the water wells onsite and located within a half-mile radius of the disposal site or property boundaries. Each well should be given a unique ID that can be cross referenced from the map to the table. Fill in the well use (private, public, livestock, etc); state whether the well is producing (yes or no); whether the well is open, cased, capped, or plugged; and the proposed best management practice for that well. In addition, provide aspects of well construction such as casing, yield, static elevation, water quality, and age for each well. Submit copies of State Water Well Reports (drillers' logs, completion data), and data on depths to ground water for water supply wells including a description of how the depths to ground water were obtained. Well reports may be obtained by contacting the Central Records Offices of TCEQ at (512)239-0900. An additional source of well reports is online at the Texas Water Development Board website: <http://wiid.twdb.state.tx.us>. Local groundwater resources below the wastewater application site shall be monitored to establish preoperational baseline groundwater quality for the following: total dissolved solids, nitrate-nitrogen, chlorides, sulfates, pH, and Coliform bacteria.

Indicate whether groundwater monitoring wells or lysimeters are planned around the land application site. If yes, then a map identifying the proposed location of the monitoring wells or lysimeters should be submitted, along with the proposed depth of the wells or lysimeters, proposed sampling schedule, and proposed monitoring parameters.

7. SOIL MAP AND SOIL ANALYSES

- a. Accurately locate the area to be used for land application on a U.S. Department of Agriculture (USDA) Natural Resources Conservation Service (NRCS) Soil Survey Map. Updated soil information may be obtained from NRCS at <http://www.tx.nrcs.usda.gov/>. Include engineering properties (No. 200 Sieve, Liquid Limit, Plasticity), soil permeability for each texture class, and seasonal high water table. Soil evaluations will be provided with all the information required in 30 TAC Section 222.73. See Instructions for Domestic Worksheet 3.3, subsection 2 Required Plans.
- b. Provide analyses of the soil in the land application area for pH [2:1 (v/v) water/soil mixture]; electrical conductivity [2:1 (v/v) water/soil mixture]; sodium adsorption ratio (SAR) from a water saturated paste and its constituent parameters (water-soluble Na, Ca and Mg reported in mg/L); total Kjeldahl nitrogen (TKN); total nitrogen (organic-nitrogen + nitrate-nitrogen + ammonium-nitrogen); nitrate-nitrogen (from a 1 N KCl soil extract); potassium, phosphorous; calcium; magnesium; sulfur; and sodium. The nutrient parameters should be analyzed on a plant-available basis. Phosphorus shall be analyzed according to the Mehlich III procedure with inductively coupled plasma and potassium, calcium, magnesium, sodium, and sulfur may also be analyzed in the Mehlich III soil extract. Plant-available phosphorus, potassium, calcium, magnesium, sodium and sulfur shall be reported on a dry weight basis in mg/kg; electrical conductivity, in mmho/cm [same as deciSiemens/meter (dS/m)]; and pH, in standard units. When reporting the results, include all information concerning fertilizer recommendations. Provide a copy of this plan to the analytical laboratory prior to sample analysis.

Composite or benchmark sampling techniques should be used when sampling the soils of the wastewater application area. Individual soil types, as defined by the USDA Soil Conservation Service Soil Survey, should be sampled individually at zones 0-6, 6-18, and 18-30 inches. Each composite sample must represent no more than 80 acres with no less than 15 subsamples representing each composite sample. Each benchmark sample must represent no more than 80 acres with at least 7 subsamples for each benchmark composite sample. Subsamples must be compo-sited by individual site, zone, and soil type for analysis and reporting

Provide the information requested on the soil table, including the soil series name; total depth of the soil series; permeability of the soil series by depth; and available water capacity of the soil series by depth.

8. EFFLUENT MONITORING DATA

This item is required for all renewal and amendment applications. Provide the monitoring data for the previous 2 years (for a minimum of 24 months) for the parameters regulated in the current permit. Provide the 30-day average data if the permit includes a 30-day average limit. If the permit includes only a single grab limit, provide the maximum single grab value for the month. This information is not required for a new permit application unless the facility's permit expired and operation continued.

Provide the daily average flow (30-day average) in gallons per day for each month and the total number of acres irrigated. Explain any persistent excursions and discuss any corrective actions for the parameter(s) shown in item 5 and for pH, chlorine residual or other parameters regulated in the current permit.

**INSTRUCTIONS FOR DOMESTIC WORKSHEET 3.1
SURFACE LAND DISPOSAL OF EFFLUENT
NEW AND AMENDMENT***

Worksheet 3.1 is required if 1) you are currently authorized to utilize land application for disposal of effluent AND 2) this permit application is requesting changes from your existing permit conditions OR 3) you are seeking a new authorization for the land application for disposal of effluent by either a new permit application or an amendment application of an existing facility not currently authorized for land disposal of effluent.

*** This worksheet may be requested for renewal applications on a case by case basis.**

1. LAND APPLICATION REQUIREMENTS

Complete the applicable section and provide water balance and storage calculations, as needed. An example of a water balance and storage calculation is provided as Example 10.

- a.** For the area under irrigation, provide the following: acres irrigated; design application frequency in hour per day and days per week; the average and maximum slope of the irrigation site; the design application rate in acre-feet/area/year; the design total nitrogen loading rate. Describe the application method and equipment, (e.g., row irrigation, spray irrigation using a center pivot sprinkler system, etc.) Estimate the irrigation efficiency.

Irrigation shall be limited to prevent excessive nitrogen application. The annual liquid loading shall not exceed that which would introduce more nitrogen than is annually required by the crop plus 20% volatilization. Values for crop nitrogen requirements shall be justified in the design report. The application rate shall be calculated by the formula $L = N/2.7C$, where L is the annual liquid loading in acre-feet, C is the effluent nitrogen concentration in mg/l, and N is the annual crop requirement of nitrogen plus 20% volatilization in pounds per acre per year. The nitrogen loading rate will not be the limiting factor for most land disposal permits.

Provide a separate engineering report of water balance and storage volume calculation according to 30 TAC Section 309.20, Subchapter C, Land Disposal of Sewage Effluent. Provide a nitrogen balance for the crop system.

- b.** For evaporation ponds, provide a separate engineering report of evaporation calculations for average long term conditions and worse case conditions (i.e., high rainfall and low evaporation from the past 25 years of climatological data). The evaporation calculation consists of items 12 - 20 of the water balance and storage calculation. For column 13, provide the amount of effluent sent to the evaporation pond (normally the permitted flow converted to inches per month per acre of surface area of the evaporation pond(s)).
- c.** Provide the requested information on the evapotranspiration beds. Describe any lining to protect groundwater. Provide a separate engineering report of water balance and storage volume calculations.
- d.** For overland flow, describe the method of application and design requirements according to 30 TAC Section 217

2. EDWARDS AQUIFER RECHARGE AREA

Indicate yes or no whether the waste disposal activities are subject to 30 TAC Chapter 213, Edwards Aquifer Rules. If yes, provide a report that describes the surface geologic units present in the proposed land application site and identifies the location and extent of any significant recharge areas in the land application site.

**INSTRUCTIONS FOR DOMESTIC WORKSHEET 3.2
SUBSURFACE LAND DISPOSAL OF EFFLUENT
NEW AND AMENDMENT***

Worksheet 3.2 is required if 1) you are currently authorized to utilize land application for disposal of effluent AND 2) this permit application is requesting changes from your existing permit conditions OR 3) you are seeking a new authorization for the land application for disposal of effluent by either a new permit application or an amendment application of an existing facility not currently authorized for land disposal of effluent.

*** This worksheet may be requested for renewal applications on a case by case basis.**

Note: This worksheet applies to any subsurface disposal system that does **not** meet the definition of a subsurface area drip dispersal system as defined in 30 TAC 222–Subsurface Area Drip Dispersal System.

1. SUBSURFACE APPLICATION

For subsurface soil absorption, check the type of system being used/proposed. Provide all the requested information that is specific to the type of system used/proposed. Provide a separate engineering report of the water balance and storage calculation as required in 30 TAC Section 309.20, Subchapter C, Land Disposal of Sewage Effluent.

Note: For all proposed and existing subsurface disposal systems, the Class V injection Well Inventory/Authorization Form (Worksheet 7.0) must be submitted in accordance with 30 TAC Chapter 331. See Instructions for Worksheet 7.0 for further guidance.

2. EDWARDS AQUIFER RECHARGE AREA

Indicate whether the subsurface system is located on the Edwards aquifer recharge zone as designated in 30 TAC Chapter 213, Edwards Aquifer Rules. The official Edwards Aquifer boundaries can be viewed at <http://gis2.tceq.state.tx.us/website/iredwards1/viewer.htm>. Indicate whether the subsurface system is located on the Edwards aquifer transition zone as designated in 30 TAC Chapter 213, Edwards Aquifer Rules. If the subsurface system is located on the Edwards aquifer recharge zone or the Edwards aquifer transition zone, then the system may be prohibited by 30 TAC Section 213.8. Call the Wastewater Permitting Section at (512) 239-4433 to determine if the proposed activity is affected by this rule.

**INSTRUCTIONS FOR DOMESTIC WORKSHEET 3.3
SUBSURFACE AREA DRIP DISPERSAL SYSTEMS
NEW AND AMENDMENT***

Worksheet 3.3 is required if 1) you are currently authorized to utilize land application for disposal of effluent AND 2) this permit application is requesting changes from your existing permit conditions OR 3) you are seeking a new authorization for the land application for disposal of effluent by either a new permit application or an amendment application of an existing facility not currently authorized for land disposal of effluent.

*** This worksheet may be requested for renewal applications on a case by case basis.**

1. SUBSURFACE AREA DRIP DISPERSAL SYSTEM

Describe the subsurface area drip dispersal system that is being proposed or used at this facility to include at a minimum, remote control capability of the automated drip dispersal system, description of the filters prior to entering the dispersal system, distance between drip lines, distance between emitters in a drip line, rating of each emitter (G/hr), flushing capability of the dispersal system, placement of drip lines [surface or below ground level (depth)], number of dosings or cycles per day, duration of each dosing, time elapsed between the end of one dosing and the beginning of the next dosing, number of dispersal zones, days per week that irrigation is proposed.

For the information regarding irrigation operations, provide the following: acres irrigated; the average and maximum slope of the irrigation site; depth to groundwater; infiltration rate of the soils; and the effluent conductivity in dS/m (same as mmhos/cm).

For the information regarding irrigation operations, provide the following: acres irrigated; the average and maximum slope of the irrigation site; depth to groundwater; infiltration rate of the soils; and the effluent conductivity in mmhos/cm.

Note: For all proposed and existing subsurface disposal systems, the Class V injection Well Inventory/Authorization Form (Worksheet 7.0) must be submitted in accordance with 30 TAC Chapter 331. See Instructions for Worksheet 7.0 for further guidance.

2. REQUIRED PLANS

For new facilities or facilities proposing to expand a subsurface area drip dispersal system, indicate that a Recharge Feature Plan is provided with all information required in 30 TAC Section 222.79.

For new facilities or facilities proposing to expand a subsurface area drip dispersal system, indicate that a Soil evaluation is provided with all information required in 30 TAC Section 222.73. The soil evaluation shall contain at a minimum, at least one profile hole per soil type and its description; total depth of the profile hole; primary rooting depth (depth where most plant roots are concentrated); secondary rooting depth (base of primary rooting depth to the depth where plant roots are no longer discernible); description of each soil horizon to include description of its texture, structure, color, presence of mottling and percent coarse fragments; restrictive horizons; potential water bearing zones; and active water bearing zones. Soil evaluations are to be performed by a licensed Texas professional geoscientist or engineer qualified in the subject.

For new facilities or facilities proposing to expand a subsurface area drip dispersal system, indicate that a Site Preparation Plan is provided with all information required in 30 TAC Section 222.75. This plan will list the soil limitations of the affected area and how each limitation will be not restrict the intended use of the affected area. This plan must include the following, if applicable: A site plan to minimize rainfall run-on and maximize rainfall runoff from the dispersal zones, design criteria to compensate for any restrictive horizon within the soil column, soil importation with descriptions of the chemical and physical characteristics of the proposed import material, and any planned removal of existing vegetation and large stones from the terrain surface to 12 inches below the proposed placement of the drip lines.

3. FLOODWAY DESIGNATION

Indicate whether the subsurface area drip dispersal system is within a designated floodway. New or expanding subsurface area drip dispersal system are not permitted in a designated floodway. Provide the source of data used to determine the floodway.

4. SURFACE WATERS IN THE STATE

Indicate that a map is provided that shows the buffers required for surface waters in the state, water wells, and springs/seeps as required in 30 TAC Section 222.81. The acreage of the buffers should be calculated and removed from the acreage calculated for the total land application acreage.

If a facility is existing, a variance may be requested from the surface waters in the state buffer distances provided that the variance is in accordance with 30 TAC Section 222.81. Indicate whether a variance will be requested for the surface waters in the state and provide all information required in 30 TAC 222.81.

5. EDWARDS AQUIFER RECHARGE AREA

Indicate whether the subsurface area drip dispersal system and/or wastewater treatment plant is located on the Edwards aquifer recharge zone as designated in 30 TAC Chapter 213, Edwards Aquifer Rules. The official Edwards Aquifer boundaries can be viewed at <http://gis2.tceq.state.tx.us/website/iredwards1/viewer.htm>. Indicate whether the subsurface area drip dispersal system and/or wastewater treatment plant is located on the Edwards aquifer transition zone as designated in 30 TAC Chapter 213, Edwards Aquifer Rules. If the subsurface area drip dispersal system and/or wastewater treatment plant is located on the Edwards aquifer recharge zone or the Edwards aquifer transition zone, then the system may be prohibited by 30 TAC Section 213.8. Call the Wastewater Permitting Section at (512) 239-4433 to determine if the proposed activity is affected by this rule.

INSTRUCTIONS FOR DOMESTIC WORKSHEET 4.0 POLLUTANT ANALYSES REQUIREMENTS

Existing facilities that discharge directly into surface waters of the state and that meet the following requirements, shall provide pollutant analyses of the effluent discharge in this attachment:

1. Facilities with a design/permitted flow of 1.0 MGD or greater;
2. For facilities with multiple permit phases, facilities with an authorized or proposed phase at a design flow of 1.0 MGD or greater; or
3. Facilities where the applicant is a POTW that has or is required to have an approval pretreatment program; unless the facility is a minor (less than 1.0 MGD) **AND** the applicant has submitted certification to the Storm Water & Pretreatment Team that the facility does not have SIUs

FACILITIES THAT DISPOSE OF EFFLUENT VIA LAND APPLICATION, WITHOUT AUTHORIZATION TO DISCHARGE INTO WATERS IN THE STATE, ARE NOT REQUIRED TO COMPLETE AND SUBMIT THIS WORKSHEET.

TABLE 1 AND TABLE 2 SHOULD BE COMPLETED WITH THE POLLUTANT ANALYSES RESULTS BY THE APPLICANT'S AUTHORIZED LABORATORY REPRESENTATIVE. ALL LABORATORY SHEETS (RESULT SHEETS, QA/QC SHEETS, CHAIN-OF-CUSTODY) FOR ALL TESTS SHOULD BE SUBMITTED WITH THE APPLICATION AND SIGNED BY THE APPLICANT'S AUTHORIZED LABORATORY REPRESENTATIVE.

ANALYTICAL DATA PROVIDED IN THE APPLICATION MUST BE SAMPLED NO LATER THAN ONE YEAR PRIOR TO THE DATE THE APPLICATION IS SUBMITTED TO THE TCEQ.

All sampling and laboratory testing methods should be performed according to 30 TAC Chapter 319, General Regulations Incorporated into Permits. All testing shall conform to EPA approved methodologies for sample collection, preservation, analysis, and detection levels. In addition, this data must comply with the QA/QC requirements of 40 CFR Part 136 and other appropriate QA/QC requirements for standard and suggested methods for analytes not addressed by 40 CFR Part 136.

Test methods shall be sensitive enough to detect the pollutants at the Minimum Analytical Level (MAL). These values are subject to change and you may wish to contact the TCEQ Municipal Permitting Team at (512) 239-4671 before requesting these tests. Failure to use tests capable of meeting the MAL may compromise the analyses and retesting may be required. See the following TABLE 3 for MALs, suggested method of analyses and other information for these pollutants.

Report an average and a maximum value and indicate the number of samples analyzed if more than one analytical result is available. Provide the type of sample (grab or composite) and the date and time the sample(s) was collected. Indicate units if different from micrograms per liter (ug/l). Provide a definition for any abbreviation or acronyms used in completing the analytical tables.

1. TABLE 1

Provide the results of an analysis of the treated effluent for these pollutants included in the Texas Surface Water Quality Standards at 30 TAC Section 307.6.

Tributyltin: Please note that not all facilities are required to test for Tributyltin; testing will be required for domestic facilities that receive wastewater from the types of industrial/commercial operations listed as follows:

1. Manufacturers and formulators of tributyltin or related compounds, including, but not limited to SIC code 2879.
2. Painting of ships, boats and marine structures, including, but no limited to SIC code 1721.
3. Ship and boat building and repairing, including, but no limited to SIC codes 3731, 3732 and 3441.
4. Ship and boat cleaning, salvage, wrecking and scaling, including, but not limited to SIC codes 4499 and 7699.
5. Operation and maintenance of marine cargo handling facilities and marinas, including, but not limited to SIC codes 4491 and 4493.
6. Facilities engaged in wood preserving, including, but not limited to, SIC code 2491.
7. Any other industrial/commercial facility for which tributyltin is known to be present, or for which there is any reason to believe that tributyltin may be present in the effluent.

2. TABLE 2

Provide the results of an analysis of the treated effluent for these priority pollutants. The suggested Method of Analysis is shown as follows for those additional pollutants contained in TABLE 2 that are not listed in TABLE 3:

<u>Pollutant</u>	<u>MAL (ug/l)</u>	<u>Suggested Method</u>
Antimony	60	200.7
Beryllium	5	200.7
Phenols, Total	10	625
Thallium	10	279.2
Volatile Compounds	see Table 3	624
Acid Compounds	see Table 3	625
Base/Neutral Compounds	see Table 3	625
Pesticides	see Table 3	608

TABLE 3

MINIMUM ANALYTICAL LEVELS FOR APPLICATION SCREENING

POLLUTANT	CASRN*	MAL ug/l	Suggested Method
Aldrin	309-00-2	0.05	608
Alphahexachlorocyclohexane	319-84-6	0.05	608
Aluminum	7429-90-5	30	202.2
Arsenic	7440-38-2	10	206.2

POLLUTANT	CASRN*	MAL ug/l	Suggested Method
Barium	7440-39-3	10	208.2
Benzene	71-43-2	10	624
Benzidine	92-87-5	50	625
Benzo [a] anthracene	56-55-3	10	625
Benzo [a] pyrene	50-32-8	10	625
betahexachlorocyclohexane	319-85-7	0.05	608
Bis(chloromethyl)ether	542-88-1	Hydrolyzes in water.	Will not require applicant to analyze at this time.
Cadmium	7440-43-9	1	213.2
Carbon Tetrachloride	56-23-5	10	624
Carbaryl	63-25-2	5	632
Chlordane	57-74-9	0.15	608
Chlorobenzene	108-90-7	10	624
Chloroform	67-66-3	10	624
Chlorpyrifos	2921-88-2	0.05	1657
Chromium	7440-47-3	10	218.2
Hexavalent Chromium	18540-29-9	10	218.4
Trivalent Chromium	16065-83-1	Determined by subtracting Hexavalent Cr from Total Cr.	
p-Chloro-m-Cresol	59-50-7	10	625
4,6-Dinitro-o-Cresol	534-52-1	50	625
p-Cresol	106-44-5	10	625
Copper	7440-50-8	10	220.2
Chrysene	218-01-9	10	625
Total Cyanide	57-12-5	20	335.2
Cyanide, Amenable to Chlorination	57-12-5	20	335.1
Cyanide, Weak Acid Dissociable	57-12-5	20	4500-CN I.
4,4'-DDD	72-54-8	0.1	608
4,4'-DDE	72-55-9	0.1	608
4,4'-DDT	50-29-3	0.1	608
2,4'-D	97-75-7	10	615
Danitol	39515-41-8	EPA procedure not approved.	Will not require applicant to analyze at this time.
Demeton	8065-48-3	0.20	1657
Diazinon	333-41-5	0.5	1657
Dibromochloromethane	124-48-1	10	624

POLLUTANT	CASRN*	MAL ug/l	Suggested Method
1,2-Dibromoethane	106-93-4	2	618
Dieldrin	60-57-1	0.1	608
1,4-Dichlorobenzene	106-46-7	10	625
1,2-Dichloroethane	107-06-2	10	624
1,1-Dichloroethylene	75-35-4	10	624
Dicofol	115-32-2	20	617
Dioxins/Furans(TCDD Equivalents)			1613
2,3,7,8-TCDD	1746-01-6	10 ⁻⁵ or ppq	
1,2,3,7,8-PeCDD	40321-76-4	50	
2,3,7,8-HxCDDs			
1,2,3,4,7,8-HxCDD	39227-28-6	50	
1,2,3,6,7,8-HxCDD	57653-85-7	50	
1,2,3,7,8,9-HxCDD	19408-74-3	50	
2,3,7,8-TCDF	51207-31-9	10	
1,2,3,7,8-PeCDF	57117-41-6	50	
2,3,4,7,8-PeCDF	57117-31-4	50	
2,3,7,8-HxCDFs			
1,2,3,4,7,8-HxCDF	70648-26-9	50	
1,2,3,6,7,8-HxCDF	57117-44-9	50	
1,2,3,7,8,9-HxCDF	72918-21-9	50	
2,3,4,6,7,8-HxCDF	60851-24-5	50	
Diuron	330-54-1	0.09	632
Endosulfan I (Alpha)	959-98-9	0.1	608
Endosulfan II (Beta)	33213-65-9	0.1	608
Endosulfan sulfate	1031-07-8	0.1	608
Endrin	72-20-8	0.1	608
Fluoride	16984-48-8	500	340.3
Gammahexachlorocyclohexane(Lindane)	58-89-9	0.05	608
Guthion	86-50-0	0.1	1657
Heptachlor	76-44-8	0.05	608
Heptachlor Epoxide	1024-57-3	1.0	608
Malathion	121-75-5	0.1	1657
Hexachlorobenzene	118-74-1	10	625
Hexachlorbutdiene	87-68-3	10	625
Hexachloroethane	67-72-1	20	625
Hexachlorophene	70-30-4	10	604.1
Lead	7439-92-1	5.0	239.2
Mercury	7439-97-6	0.2	245.1
Methoxychlor	72-43-5	2.0	617
Methyl Ethyl Ketone	78-93-3	50	624
Mirex	2385-85-5	0.2	617
Nitrate-Nitrogen	14797-55-8	1000	352.1

POLLUTANT	CASRN*	MAL ug/l	Suggested Method
Nickel	7440-02-0	10	249.2
Nitrobenzene	98-95-3	10	625
N-Nitrosodiethylamine	55-18-5	20	625
N-Nitroso-di-n-Butylamine	924-16-3	20	625
Parathion	56-38-2	0.1	1657
Pentachlorobenzene	608-93-5	20	625
Pentachlorophenol	87-86-5	50	625
Phenanthrene	85-01-8	10	625
Polychlorinated Biphenyls(PCBs) The sum of seven PCB congeners 1242, 1254, 1221, 1232, 1248, 1260, and 1016.			
PCB-1232	11141-16-5	1.0	608
PCB-1242	53469-21-9	1.0	
PCB-1254	11097-69-1	1.0	
PCB-1221	11104-28-2	1.0	
PCB-1248	12672-29-6	1.0	
PCB-1260	11096-82-5	1.0	
PCB-1016	12674-11-2	1.0	
Pyridine	110-86-1	20	625
Selenium	7782-49-2	10	270.2
Silver	7440-22-4	2.0	272.2
1,2,4,5-Tetrachlorobenzene	95-94-3	20	625
Tetrachloroethylene	127-18-4	10	624
Toxaphene	8001-35-2	5.0	608
2,4,5-TP (Silvex)	93-72-1	2.0	615
Selenium	7782-49-2	10	270.2
Silver	7440-22-4	2.0	272.2
1,2,4,5-Tetrachlorobenzene	95-94-3	20	625
Tetrachloroethylene	127-18-4	10	624
Toxaphene	8001-35-2	5.0	608
2,4,5-TP (Silvex)	93-72-1	2.0	615
Tributyltin	688-73-3	0.010	TCEQ 1001
2,4,5-Trichlorophenol	95-95-4	50	625
Trichloroethane	79-01-6	10	624
1,1,1-Trichloroethane	71-55-6	10	624
TTHM (Total) Chloroform Bromoform Dichlorobromomethane Chlorodibromomethane	67-66-3 75-25-2 75-27-4 124-48-1	10 10 10 10	624
Vinyl Chloride	75-01-4	10	624
Zinc	7440-66-6	5.0	289.2

* Chemical Abstracts Service Registry Number

INSTRUCTIONS FOR DOMESTIC WORKSHEET 5.0 - WHOLE EFFLUENT TOXICITY (WET) TESTING REQUIREMENTS

If the application includes the following, complete and submit this attachment:

1. facilities with a currently-operating design flow greater than or equal to 1.0 MGD;
2. applicants with an EPA-approved pretreatment program (or those that are required to have one under 40 CFR Part 403); unless the facility is a minor (less than 1.0 MGD) **AND** the applicant has submitted certification to the Storm Water & Pretreatment Team that the facility does not have SIUs or
3. other facilities required by the TCEQ to perform Whole Effluent Toxicity testing.

OUTFALLS WHERE ROUTINE TOXICITY TESTING IS BEING CONDUCTED AS A REQUIREMENT OF THE CURRENT PERMIT DO NOT NEED TO RETEST OR SUBMIT TEST RESULTS.

At a minimum, these results must include quarterly testing for a 12-month period within the past year or annual testing over the previous four and one-half years prior to submission of the application. A minimum of two species, as specified by the permit (where applicable), must be used. Therefore, the applicant must submit, at a minimum, the results of eight tests. These results will be used to determine reasonable potential for the facility's effluent to effect toxicity in the receiving waters at the discharge location.

If the application is for a new discharge or for a permit that does not currently specify WET testing and still meets one of the three criteria listed above, the applicant may contact the Water Quality Standards Team of the Water Quality Division to obtain the appropriate information (e.g., freshwater versus saltwater, acute versus chronic) to perform the application WET testing. If the applicant prefers not to obtain the site-specific information, quarterly testing using chronic test species and a dilution series of 6%, 13%, 25%, 50%, and 100% may be performed instead.

All testing must be in accordance with 40 CFR Part 136 methods, TPDES permit requirements (where applicable), QA/QC requirements of 40 CFR Part 136, and other appropriate QA/QC requirements for standard methods for analytes not addressed by 40 CFR Part 136.

In addition, the applicant must submit the results of any other WET tests from the past four and one-half years. If any of those tests demonstrated toxicity, provide any information on the cause or any results of a Toxicity Reduction Evaluation (TRE), if one was conducted.

If the information requested in this section had been previously submitted to the TCEQ as specified by the applicant's current permit, the information need not be resubmitted via Parts 1 and 2 of Worksheet 5.0. Instead, the applicant must follow the instructions in Part 4 of Worksheet 5.0 and provide a table summarizing the previously performed testing.

Test summaries (full reports) that provide all of the information requested in Parts 1 and 2 of Worksheet 5.0 may be submitted in place of parts 1 and 2 of Worksheet 5.0.

If no WET testing is required, do not complete Worksheet 5.0.

INSTRUCTIONS FOR DOMESTIC WORKSHEET 6.0 INDUSTRIAL WASTE CONTRIBUTION

ALL PUBLICLY OWNED TREATMENT WORKS (POTWs) must provide the industrial waste contribution information in Worksheet 6.0. Privately-owned facilities are **not** required to complete and submit this attachment.

1. ALL POTWs

- a.** Provide the number of each of the listed types of industrial users that discharge to your POTW. Provide the total flow from each type of industrial user. The definition of each type of industrial user can be found in the Definitions section of the instructions.
- b.** Answer yes or no whether the POTW has experienced treatment plant interference in the past three years. The definition of interference can be found in the Definitions section of the instructions. If the POTW has experienced interference, provide all dates, duration, description of the interference, probable cause(s), and possible source(s) in the space provided. Submit a separate attachment if necessary.
- c.** Answer yes or no whether the POTW has experienced treatment plant pass through in the past three years. The definition of pass through can be found in the Definitions section of the instructions. If the POTW has experienced pass through, provide all dates, description of pollutants passing through the treatment plant, probable cause(s), and possible source(s) in the space provided. Submit a separate attachment if necessary.
- d.** Answer the question yes or no whether the POTW has an approved pretreatment program or is developing an approved pretreatment program. If no, skip item 2 and answer all questions in item 3 for each significant industrial user. If yes, answer all questions in item 2, but skip item 3 questions.

2. POTWs WITH APPROVED PROGRAMS OR THOSE REQUIRED TO DEVELOP A PROGRAM

- a.** Answer yes or no whether there have been any substantial modifications to the POTW's approved pretreatment program that have not been approved according to 40 CFR Section 403.18. If yes, identify on a separate attachment all substantial and nonsubstantial modifications that have not been submitted to the Approval Authority (TCEQ).
- b.** List any and all parameters measured above the MAL in your POTW's effluent during the past three years annual monitoring scans according to the requirements in the pretreatment section of your TPDES permit. If retests were done following the above annual testing for any parameters identified in your POTW's effluent above the MAL, identify all retest parameters, concentrations, MALs and dates. Attach additional sheets as necessary.
- c.** Answer the question yes or no whether the SUI has caused or contributed to any problems. Provide information concerning any problems the treatment works have experienced that are attributable to discharges from SIUs. Problems may include Acts of God, interferences or pass through at the plant, corrosion in the collection system, or other similar events.

3. SIGNIFICANT INDUSTRIAL USER INFORMATION

POTWs THAT DO NOT HAVE AN APPROVED PRETREATMENT PROGRAM ARE REQUIRED TO PROVIDE THE INFORMATION IN ITEM NO. 3. (POTWs that have an approved pretreatment program do not need to complete item 3 UNLESS this is a new wastewater treatment plant or SIUs have commenced discharge to an existing plant where none have been discharging previously.)

- a.** Provide the name, address and requested information of each SIU, as defined in 40 CFR Part 403, discharging to your POTW. (Submit additional pages as necessary.)
- b.** Describe the actual process(es) (rather than simply listing them) at the SIU that affect or contribute to the SIU's discharge. For example, in describing a metal finishing operation, include such information as how the product is cleaned prior to finishing, what types of plating baths are in operation (e.g., nickel, chromium), how paint is applied, and how the product is polished. Attach additional sheets if necessary.
- c.** List principal product(s) that the SIU generates, the raw materials and the rate at which those raw materials are used to manufacture the product(s).
- d.** Flow rate. Process wastewater means any water that, during manufacturing or processing, comes in direct contact with or results from the production or use of any raw material, intermediate product, finished product, byproduct, or waste product. Indicate the average daily volume, in gallons per day, of process wastewater and non-process wastewater that the SIU discharges into the collection system. Specify whether discharges are continuous or batch (non-continuous).
- e.** Indicate whether the SIU is subject to technically based local limits (TBLLs) and/or categorical pretreatment standards. Technically based local limits are enforceable local requirements developed by treatment works to address federal standards as well as State and local regulations and requirements. Categorical Pretreatment Standards are national technology-based standards developed by EPA, setting industry-specific effluent limits. These standards are implemented by 40 CFR Parts 405-471.
- f.** Provide information concerning any problems the treatment works has experienced that are attributable to discharges from the SIUs. Problems may include Acts of God, interferences or pass through at the plant, corrosion in the collection system, or other similar events.

**INSTRUCTIONS FOR DOMESTIC WORKSHEET 7.0
CLASS V INJECTION WELL
INVENTORY/AUTHORIZATION FORM**

WORKSHEET 7.0 MUST BE COMPLETED BY ALL AMENDMENT, NEW AND RENEWAL APPLICATIONS THAT INJECT TREATED VIA SUBSURFACE SYSTEMS

Facilities associated with large capacity septic systems (LCSS) (design of 5,000 gpd or greater), septic systems that accept industrial waste, and subsurface area drip dispersal systems (SADD) are required to obtain a wastewater discharge permit **and** submit the Class V inventory form. Subsurface systems include, but are not limited to drainfields, beds, trenches, pressure dosing, mound system, subsurface, or drip/trickle irrigation. For questions regarding whether the method of disposal is subsurface, contact the TCEQ Underground Injection Control Team of the Industrial and Hazardous Waste Section at 512/239-2334. With the exception of LCSS, SADD, and Septic systems that accept industrial waste, all other facilities using subsurface injection must obtain approval prior to construction, operation or conversion.

For assistance in completing Worksheet 7.0, please contact the TCEQ Underground Injection Control Team at (512) 239-2334. Please complete and return Worksheet 7.0 separately to the following address:

**TCEQ
Industrial and Hazardous Wastes Permits Section (MC 130)
P.O. Box 13087
Austin, Texas 78711-3087**

INSTRUCTIONS FOR TCEQ CLASS V INJECTION WELL INVENTORY/AUTHORIZATION FORM

Submit an original and one copy of the inventory /authorization form to the TCEQ Industrial and Hazardous Wastes Permits Section, MC-130, P.O. Box 13087, Austin, Texas 78711-3087.

As stated in 30 Texas Administrative Code 331.21, "All geoscientific information submitted to the agency under this chapter shall be prepared by, or under the supervision of, a licensed professional geoscientist or a licensed professional engineer and shall be signed, sealed, and dated by the licensed professional geoscientist or licensed professional engineer in accordance with the Texas Geoscience Practice Act and the Texas Engineering Practice Act." Any application submitted shall be signed, sealed and dated on the cover letter. In addition to the inventory/authorization form the TCEQ requires that a Core Data Form (Form 10400) be submitted on all incoming applications. For more information regarding the Core Data Form, call (512) 239-1575 or go to the TCEQ Web site at:

http://www.tceq.state.tx.us/permitting/central_registry/guidance.html

If you are applying for two or more Class V injection wells that are of similar construction at the same facility you may use one form. If you are applying for Class V injection wells of different construction or at different facilities then use one form per construction type and/or facility.

Complete Section I for all notifications and Sections II through V as appropriate.

The purpose of this form is to serve as the means for the Class V injection well owner or operator to provide notice to the UIC Program of intent to construct, operate, and/or convert a well in accordance with the inventory and approval requirements of 30 Texas Administrative Code 331.10. No Class V injection well may be constructed, operated and/or converted without prior approval from the executive director.

EXAMPLE 1 - WASTEWATER TREATMENT PROCESSES OR PROCESS MODIFICATIONS

Conventional plug flow activated sludge - Settled wastewater and recycled activated sludge enter the head end of the aeration tank and are mixed by diffused air or mechanical aeration. Air application is generally uniform throughout tank length. During the aeration period, adsorption, flocculation and oxidation of organic matter occurs. Activated-sludge solids are separated in a secondary settling tank.

Complete-mix activated sludge - Process is an application of the flow regime of a continuous-flow stirred-tank reactor. Settled wastewater and recycled activated sludge are introduced typically at several points in the aeration tank. The organic load on the aeration tank and the oxygen demand are uniform throughout the tank length.

Denitrification - Denitrification is the process of converting nitrate nitrogen into nitrogen gas, usually accomplished in the effluent from an activated sludge nitrification process.

Tapered aeration activated sludge - Tapered aeration is a modification of the conventional plug-flow process. Varying aeration rates are applied over the tank length depending on the oxygen demand. Greater amounts of air are supplied to the head of the aeration tank, and the amounts diminish as the mixed liquor approaches the effluent end. Tapered aeration is usually achieved by using different spacing of the air diffusers over the tank length.

Step-feed activated sludge - Step feed is a modification of the conventional plug-flow process in which the settled wastewater is introduced at several points in the aeration tank to equalize the F/M ratio, thus lowering peak oxygen demand. Generally three or more parallel channels are used. Flexibility of operation is one of the important features of this process.

Modified aeration activated sludge - Modified aeration is similar to the conventional plug-flow process except that shorter aeration times and higher F/M ratios are used. BOD removal efficiency is lower than other activated sludge processes.

Contact stabilization activated sludge - Contact stabilization uses two separate tanks or compartments for the treatment of wastewater and stabilization of activated sludge. Stabilized activated sludge is mixed with influent wastewater in a contact tank. Return sludge is aerated separately in a reaeration tank to stabilize the organic matter.

Extended aeration activated sludge- Extended aeration process is similar to the conventional plug flow process except that it operates in the endogenous respiration phase of the growth curve, which requires a low organic loading and long aeration time. This process is used extensively for prefabricated package plants for small communities and in oxidation ditch (continuous loop reactor) plants.

High-rate aeration activated sludge- High-rate aeration is a process modification in which high MLSS concentrations are combined with high volumetric loadings. This combination allows high F/M ratios and long mean cell-residence times with relatively short hydraulic detention times. Adequate mixing is very important.

Kraus process - Kraus process is a variation of the step aeration process used to treat wastewater with low nitrogen levels. Digester supernatant is added as a nutrient source to a portion of the return sludge in a separate aeration tank designed to nitrify. The resulting mixed liquor is then added to the main plug-flow aeration system.

High-purity oxygen - High-purity oxygen is used instead of air in the activated-sludge process. Oxygen is diffused into covered aeration tanks and is recirculated. A portion of the gas is wasted to reduce the concentration of carbon dioxide. pH adjustment may also be required. The amount of oxygen added is about four times greater than the amount that can be added by conventional aeration systems.

Membrane Bioreactor Systems - Membrane bioreactors combine suspended growth activated sludge treatment with membrane filtration systems, typically in a common basin. High levels of treatment can be achieved without the need for final clarification and effluent filtration.

Nitrification - Nitrification is the biological oxidation of ammonia into nitrites and then nitrates by microorganisms in the activated sludge treatment process.

Nutrient Removal - nutrient removal generally refers to the removal of nitrogen and/or phosphorus from wastewater. Biological processes, membrane filtration, sand filtration, or a combination of these processes may be used for nutrient removal.

Oxidation ditch - The oxidation ditch consists of a ring or oval shaped continuous loop activated sludge reactor and is equipped with mechanical aeration devices. Screened wastewater enters the ditch, is aerated, and circulates at a velocity of 0.8 to 1.2 ft/s (0.24 to 0.37 m/s). Oxidation ditches typically operate in the extended aeration mode with long detention and solids retention times.

Sequencing batch reactor - A fill and draw activated sludge treatment system that is identical to conventional activated sludge systems, except that the processes are carried out sequentially in the same tank. An SBR system has the following five steps that are carried out in sequence: fill, react, settle, draw, idle. Mixed liquor remains in the reactor during all cycles, thereby eliminating the need for separate secondary sedimentation tanks and return activated sludge pumps.

EXAMPLE 2 - TREATMENT UNITS

LIQUID TREATMENT PROCESSES

Primary Treatment

- 01 Pumping raw wastewater
- 02 Preliminary treatment – bar screen
- 03 Preliminary treatment – grit removal
- 04 Preliminary treatment - comminutors
- 05 Preliminary treatment - others
- B1 Imhoff tank
- 06 Scum removal
- 07 Flow equalization basins
- 08 Preaeration
- 09 Primary sedimentation
- D2 Septic tank
- A5 Facultative lagoon

Secondary Treatment

- 10 Tricking filter – rock media
- 11 Tricking filter – plastic media
- 12 Tricking filter – redwood slats
- 13 Tricking filter – other media
- 14 Activate sludge – conventional
- 15 Activate sludge – complete mix
- 16 Activate sludge – contact stabilization
- 17 Activated sludge – extended aeration
- 18 Pure oxygen activate sludge
- 19 Bio-Disc (rotating biological filter)
- 20 Oxidation ditch
- 21 Clarification using tube settlers
- 22 Secondary clarification
- B6 Constructed wetlands
- E5 Natural treatment
- E6 Overland flow

Advanced Treatment - Biological

- 23 Biological nitrification – separate stage
- 24 Biological nitrification - combined
- 25 Biological denitrification
- 26 Post aeration (reaeration)

Advanced Treatment – Physical/Chemical

- 27 Microstrainers – primary
- 28 Microstrainers – secondary
- D1 Dunbar Beds
- 29 Sand filters
- 30 Mix media filters (sand and coal)
- 31 Other filtrations
- B2 Bubble diffuser (compressor)
- 32 Activated carbon – granular
- B3 Mechanical surface aerator
- 33 Activated carbon-powered
- 34 Two stage lime treatment of raw
- 35 Two stage tertiary lime treatment
- 36 Single stage lime treatment of raw
- 37 Single state tertiary lime treatment
- 38 Recarbonation
- 39 Neutralization

- 40 Alum addition to primary
- 41 Alum addition to secondary
- 42 Alum addition to separate state tertiary
- 43 Ferri-chloride addition to primary
- 44 Ferri-chloride addition to secondary
- 45 Ferri-chloride addition to separate stage
- 46 Other chemical additions
- 47 Ion exchange
- 48 Breakpoint chlorination
- 49 Ammonia stripping
- 50 Dechlorination

Disinfection

- 51 Chlorination for disinfection
- 52 Ozonation for disinfection
- 53 Other disinfection
- D3 Ultra violet light

Land Treatment

- 54 Land treatment of primary effluent
- 55 Land treatment of secondary effluent
- 56 Land treatment of intermediate effluent (less than secondary)

Other Treatment

- 57 Stabilization ponds
- 58 Aerated lagoons
- 59 Outfall pumping
- 60 Outfall diffuser
- 61 Effluent to other plants
- 62 Effluent outfall
- 63 Other treatment
- 64 Evapo-transpiration beds
- 64 Recalcination

Disposal Method

- A7 Irrigation – public access
- A8 Irrigation – agricultural
- B4 Evapo-transpiration beds
- B6 Constructed wetlands
- C1 Irrigation – pastureland
- D4 Pressure dosing system
- D5 Percolation system
- D8 Other reuse method
- E1 Evaporation/plays
- E2 Discharge only
- E3 Discharge and (use other #)
- E4 Injection well(s)

SLUDGE TREATMENT PROCESSES

- 65 Aerobic digestion – air
- 66 Aerobic digestion – oxygen
- 67 Composting
- 68 Anaerobic digestion
- 69 Sludge lagoons
- 70 Heat treatment – dryer
- 71 Chlorine oxidation of sludge

- 72 Lime stabilization
- 73 Wet air oxidation
- 74 Dewatering – sludge drying beds, sand
- F2 Dewatering – sludge drying bed vacuum
- 75 Dewatering – mechanical-vacuum filter
- 76 Dewatering – mechanical – centrifuge
- 77 Dewatering – mechanical – filter press
- 78 Dewatering – others
- 79 Gravity thickening
- 80 Air flotation thickening
- D6 Sludge holding tank

Incineration

- 81 Incineration – multiple hearth
- 82 Incineration – fluidized beds
- 83 Incineration – rotary kiln
- 84 Incineration –others
- 85 Pyrolysis
- 86 Co-incineration with solid waste
- 87 Co-pyrolysis with solid waste
- 88 Co-incineration - others

SLUDGE DISPOSAL

- 89 Co-disposal landfill
- D7 Sludge – only monofill
- 90 Land application (permitted)
- 91 Commercial land application (register)
- 92 Trenching
- B5 Transport to another WWTP
- F3 Transport to Regional compost facility
- 94 Other sludge handling
- 95 Digest gas utilization facilities
- E7 Commercial land application (permit)
- F4 Dedicated land disposal
- F5 Marketing and distribution composted
- F6 Marketing and distribution non-composted

MISCELLANEOUS

- 96 Control/lab/maintenance buildings
- 97 Fully automated using digital control -
- 98 Fully automated using analog control
- 99 Semi-automated plant
- A1 Manually operated and controlled plant
- A2 Package plant
- A3 Semi-package plant
- A4 Custom built plant
- A7 Irrigation – public access
- A8 Irrigation – agriculture
- A9 Effluent storage ponds (irrigation)
- C1 Irrigation – pastureland
- D8 Other reuse method
- D9 Emergency holding ponds
- E1 Evaporation or plays
- E8 Monitoring wells
- E9 Biomonitoring
- F7 Stormwater (SSO)
- F8 Unconventional

EXAMPLE 3- FLOW DIAGRAM

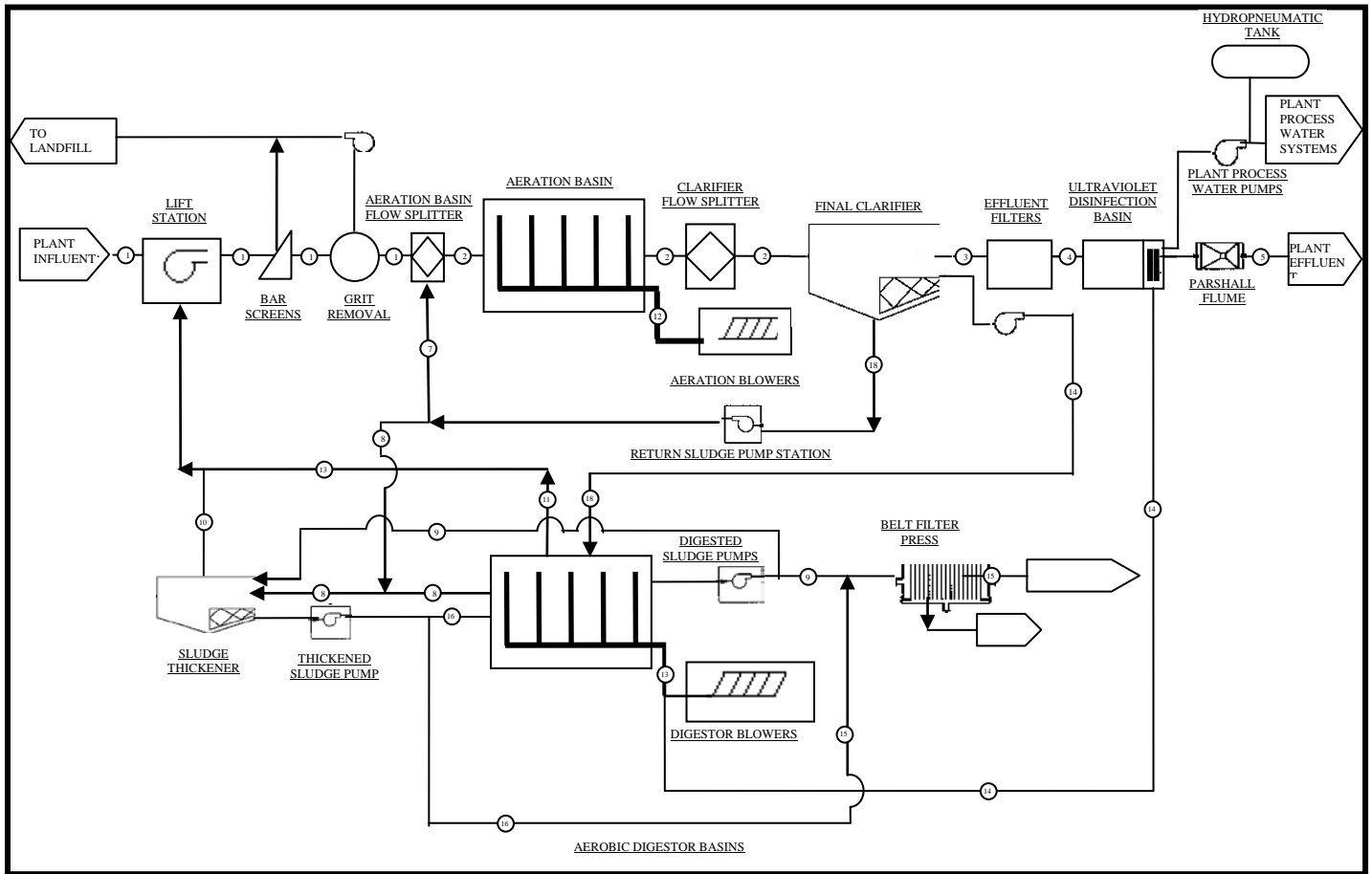

EXAMPLE 4 - DESIGN CALCULATIONS

DESIGN CALCULATIONS

Influent Quality Characteristics - The raw sewage characteristics used for design purposes are as follows:

<u>Parameter</u>	<u>Concentration</u>
BOD5	250 mg/l
TSS	240 mg/l

Influent Flow Characteristics - The hydraulic design of the facility must ensure that the plant will operate under the most extreme conditions anticipated. The plant process and hydraulic design for this facility are as follows:

<u>Flow</u>	<u>Gallons Per Day</u>	<u>Gallons Per Minute</u>
Average Daily Flow (Qave)	225,000	156
Peak 2-Hour Flow (Qpk)	900,000	625

<u>Loading</u>	<u>Pounds per day</u>
BOD5	469.4
TSS	450.7

Process Design - The treatment plant will be designed to produce an effluent quality in compliance with the proposed permitted parameters of: CBOD5 = 10 mg/l; TSS = 15 mg/l; NH3-N = 3 mg/l; Dissolved Oxygen = 4.0 mg/l; Chlorine Residual = 1 to 4 mg/l after 20 minutes detention time at peak flow. In order to achieve the required removal efficiencies, the activated sludge process operated in the conventional mode with nitrification has been chosen. The 7 day low reactor temperature is 15°. The anticipated operating ranges for MLSS and RAS are 3,000 mg/l and 6,000 mg/l respectively. Other assumptions include a single stage aerobic digester with supernatant decant and digester solids concentration of 2%.

Treatment Units	TCEQ Requirement	Actual Provided
Aeration Basin		
Organic loading rate (lbs/day/1000 ft ³)	25 (Max)	20
Total aeration volume (ft ³)	18,776	23,470
Clarifier		
Surface loading rate (Qpk)	1,200 (Max)	1,000
Detention time (Qpk) (hr)	1.8 (Min)	2.2
Surface area (ft ²)	750	908
Volume (ft ³)	9,024*	11,029
Side-water depth (ft)	10 (Min)	12
Maximum weir loading (Qpk)	20,000 (Max)	15,000
Diameter (ft)	31	34
Weir length (ft)	45	60

Treatment Units	TCEQ Requirement	Actual Provided
Aerobic Digester		
MCRT at 15°C (days)	60 (Min)	60
WAS solids production (ppd)		280
Digested sludge solids production		200
Required solids in digester (lbs)		12,000
Digester Volume (ft ³)		9,618
Chlorine Contact Chamber		
Detention time (Qpk) (minutes)	20	25
Volume (Qpk) (ft ³)	1,672	2,089
Air Requirements		
Aeration Basin		
Aeration requirements (SCF/day/lb)	3,200	3,200
Oxygen required (lb O ₂ /lb BOD ₅)	2.2	2.2
Oxygen required (lb/day)	1,032	1,032
Air provided (SCFM)	923	923
Sludge Digester		
Aeration requirements	20	26
Air Flow Rate (SCFM)	193	250

* Minimum volume needed to meet 1.8 hour detention time in Clarifier.

PLANT DESIGN FEATURES

A. EMERGENCY POWER REQUIREMENTS

In accordance with 30 TAC §217.36 and due to the number and duration of power outages that have occurred during the past 24 months, the treatment facility will incorporate an on-site automatically starting generator capable of continuously operating all critical wastewater treatment system units. The fuel tank will be sized for a run time greater than the longest power outage in the power records. This generator will provide sufficient power for the following units:

1. 3 - Influent Lift Station Pumps
2. 1 - Mechanical Bar Screen
3. 2 - Activated Sludge Mechanical Surface Aerators (one in each basin)
4. 2 - Final Clarifier Sludge Scrapers
5. 1 - Return Activated Sludge Pump
6. Chlorination system
7. Dechlorination system
8. Effluent Metering Station
9. Lighting Panels and Control Equipment

An automatic transfer switch will be included to transfer electrical loads to the generator during an outage. In accordance with 30 TAC §217.37, the disinfection system will automatically restart during a power outage and upon transfer back to the main power source.

B. ALARM FEATURES

The plant will be equipped with a Supervisory Control and Data Acquisition (SCADA) system to monitor the operation of all critical treatment units. The control room will include a computer with graphic display of the treatment units that will indicate status and alarm conditions. The computer system will include an autodialer to alert plant personnel of the following conditions:

1. Power Outage
2. Influent Lift Station Wet Well High Level
3. Bar Screen Channel High Level
4. Final Clarifier Torque Overload
5. Equipment Failure
6. Chlorine Leak Detection
7. Sulfur Dioxide Leak Detection

The autodialer will store prerecorded messages concerning each alarm condition and the procedure to be followed and will call up to 8 different phone numbers until the alarm condition is acknowledged. The influent lift station and final clarifiers will also be equipped with local alarm lights for high level and high torque respectively.

C. DESIGN FEATURES FOR RELIABILITY AND OPERATING FLEXIBILITY

1. **INFLUENT LIFT STATION:** The influent lift station will include three submersible pumps sized to meet peak flow pumping capacity with the largest unit out of service. Level switches will automatically start and stop the pumps based on influent flows and rising and falling wet well levels. High wet well level will result in an alarm condition.
2. **BAR SCREEN:** The mechanical bar screen structure will include a bypass channel with a manual screen for use when needed. Slide gates will be used to isolate each channel as required.
3. **GRIT CHAMBER:** The grit chamber will include a bypass channel and slide gates to allow the chamber to be taken out of service for maintenance and repair.
4. **AERATION BASINS:** Two aeration basins will be included, each capable of continuous operation. Piping and valves will be included to allow each unit to be individually isolated for draining, cleaning or repairs.

D. OVERFLOW PREVENTION

The following design features will be used to prevent the overflow of wastewater from treatment units.

1. Based on 5 years of historical flow data, the plant design includes a peaking factor of 3.5 to insure adequate hydraulic capacity.
2. The influent lift station will be designed with the capacity to pump peak flow with the largest single pump out of service.
3. The plant hydraulic design, including piping, channels, weirs, troughs and other features, will be sized to allow the 2-hour peak flow to pass through the plant without exceeding minimum freeboard requirements with any single treatment unit out of service.

EXAMPLE 5 - SLUDGE MANAGEMENT PLAN

Influent Design Flow = 0.225 mgd
 Influent BOD Concentration = 250 mg/l
 Aerobic Digester Volume: 71,950 gallons
 Aeration Basin MLSS: 2,000 to 3,000 mg/l

<u>Solids Generated</u>	<u>100% flow</u>	<u>75% flow</u>	<u>50% flow</u>	<u>25% flow</u>
Pounds Influent BOD5	469	352	235	117
Pounds of digested dry sludge produced*	164	123	82	41
Pounds of wet sludge produced	8,210	6,157	4,105	2,052
Gallons of wet sludge produced	984	738	492	246

*Assuming 0.35 pounds of digested dry sludge produced per pound of influent BOD5 at average temperatures and 2.0% solids concentration in the digester

Sludge will be wasted from the RAS flow stream to the aerobic digester. Sludge solids will be stabilized in the digester; supernatant will be decanted from the digester and returned to the plant headworks for treatment.

<u>Removal Schedule (days)</u>	<u>100%flow</u>	<u>75% flow</u>	<u>50% flow</u>	<u>25% flow</u>
Days between sludge removal	7	10	14	30

Liquid digested sludge will be removed from the digester for disposal on a regular basis as required. The calculated mean cell residence time (MCRT) for the digester storage volume of 71,950 gal will be approximately 73 days at 100% capacity and annual average digested sludge production of 164 ppd. The digested sludge will be transported by a registered hauler to a TCEQ authorized land application site for beneficial use.

EXAMPLE 6 - EPA EFFLUENT CATEGORICAL GUIDELINES

List of effluent limitation guidelines as found in Title 40 Code of Federal Regulation, Parts 405-471

<u>INDUSTRY</u>	<u>40 CFR PART</u>
Dairy Products Processing	405
Grain Mills	406
Canned and Preserved Fruits and Vegetables	407
Canned and Preserved Seafood Processing	408
Sugar Processing	409
Textile Mills	410
Cement Manufacturing	411
Feedlots	412
Electroplating	413
Organic Chemicals, Plastics, and Synthetic Fibers	414
Inorganic Chemicals	415
Soap and Detergent manufacturing	417
Fertilizer Manufacturing	418
Petroleum Refining	419
Iron and Steel manufacturing	420
Nonferrous Metals Manufacturing	421
Phosphate Manufacturing	422
Steam Electric Power Generating	423
Ferro alloy Manufacturing	424
Leather Tanning and Finishing	425
Glass manufacturing	426
Asbestos manufacturing	427
Rubber manufacturing	428
Timber Products Processing	429
Pulp, Paper and Paperboard	430
Builders' Paper and Board Mills	431
Meat Products	432
Metal Finishing	433
Coal Mining	434
Oil and Gas Extraction	435
Mineral Mining and Processing	436
Centralized Waste Treatment	437
Pharmaceutical Manufacturing	439
Ore Mining and Dressing	440
Transportation Equipment Cleaning	442
Paving and Roofing Materials	443
Combusters	444
Landfills	445
Paint Formulating	446
Ink Formulating	447
Gum and Wood Chemicals Manufacturing	454
Pesticide Chemicals	455
Explosives Manufacturing	457
Carbon Black Manufacturing	458
Photographic	459
Hospital	460
Battery Manufacturing	461
Plastics Molding and Forming	463
Metal Molding and Casting	464
Coil Coating	465
Porcelain Enameling	466
Aluminum Forming	467
Copper Forming	468
Electrical and Electronic Components	469
Nonferrous Metals Forming and Metal Powders	471

EXAMPLE 7(a) – ADJACENT LANDOWNERS

For applications proposing a land application of effluent

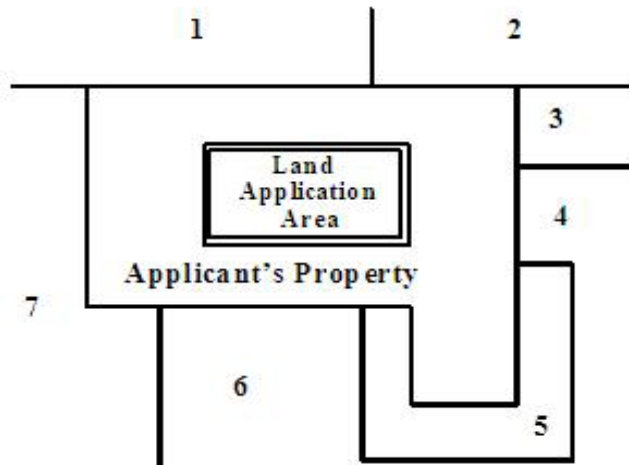

EXAMPLE 7(b) – ADJACENT AND DOWNSTREAM LANDOWNERS

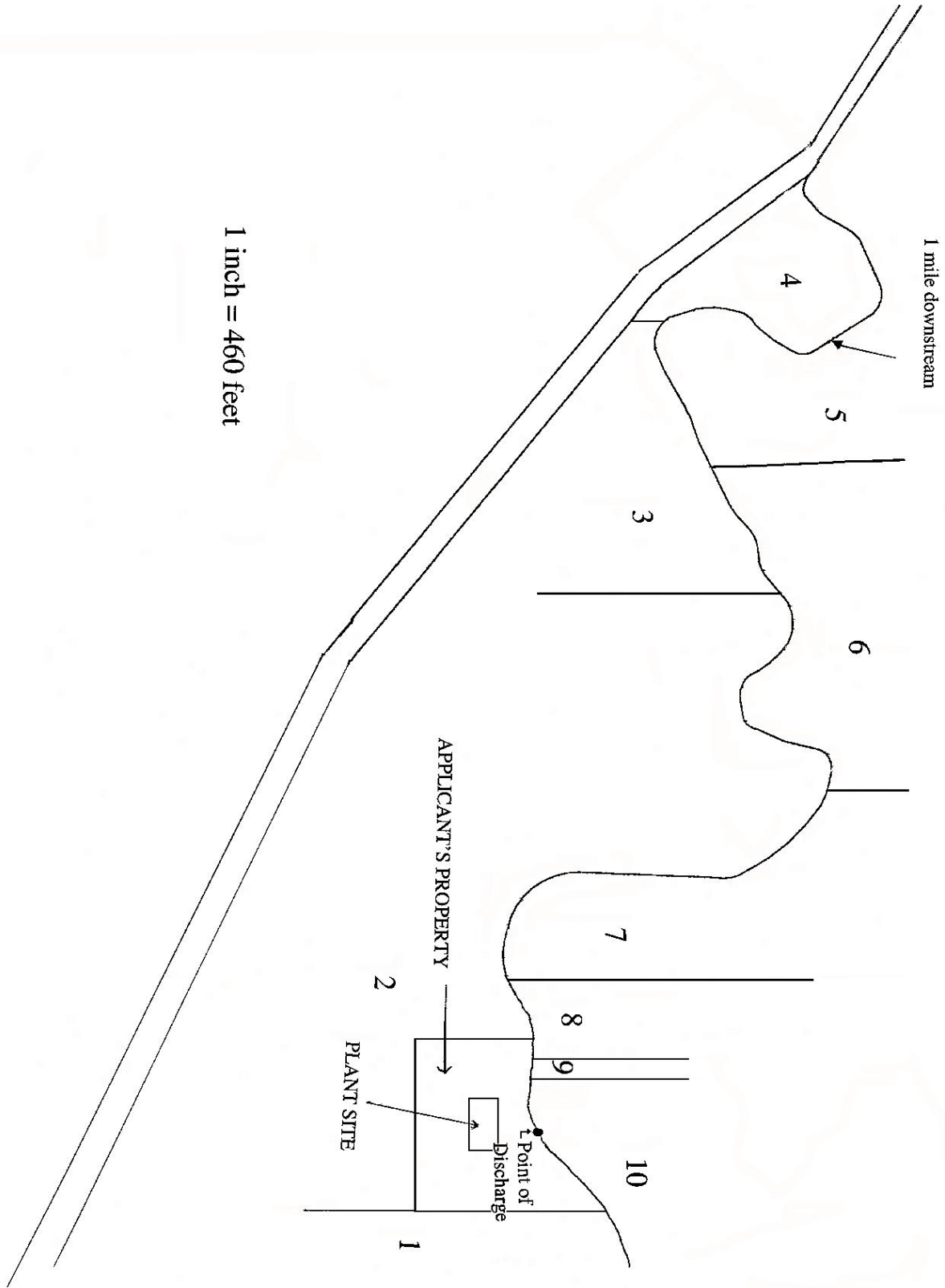

EXAMPLE 8 – BUFFER ZONE MAP

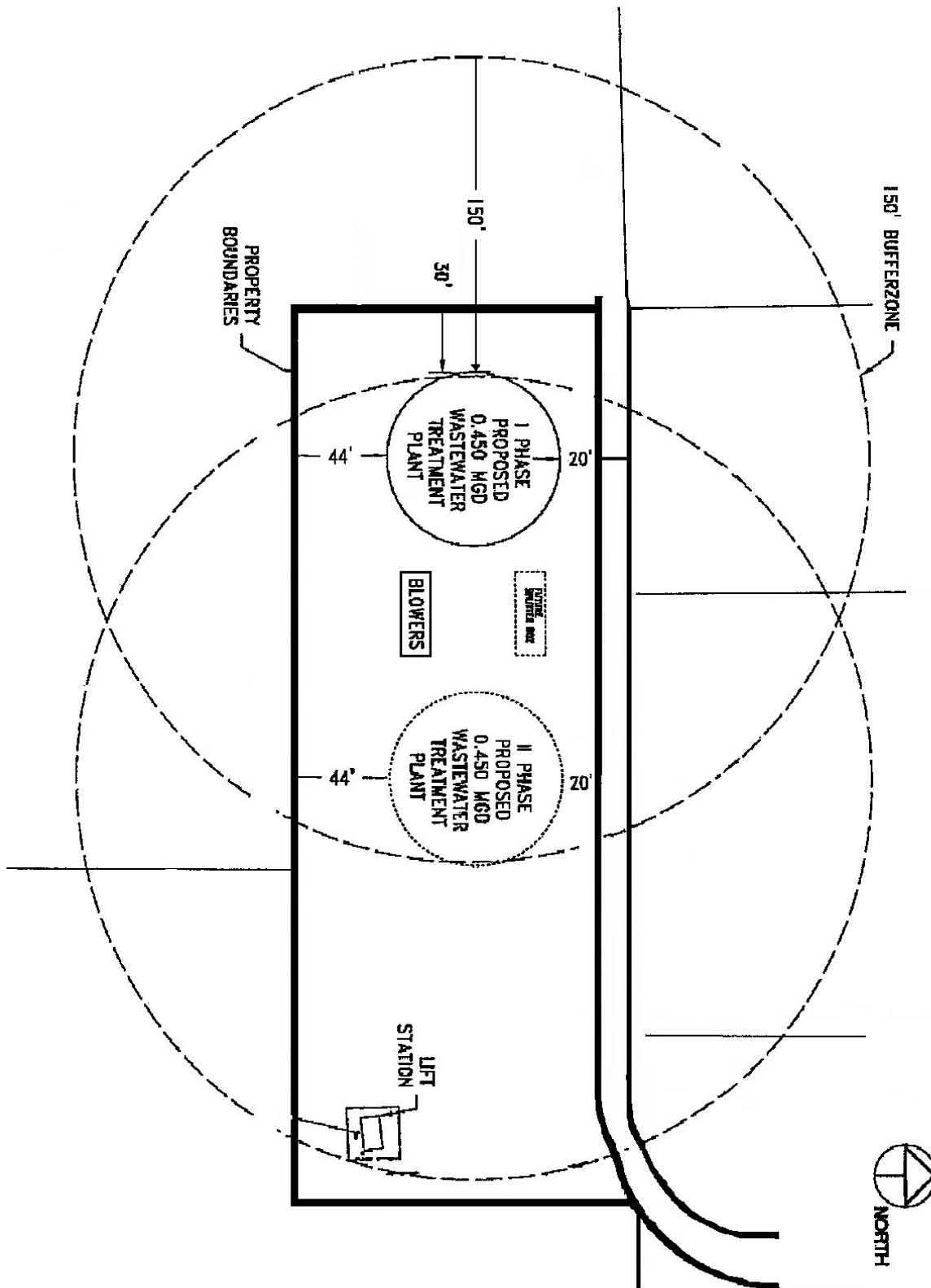

EXAMPLE 9 - WATER BALANCE AND STORAGE CALCULATION

Explanation of Tables 1 and 2

TABLE 1:

Column

- 1** Month (example calculations for each column are given for the month of January)
- 2** Average rainfall for previous 25 years: Data for Corsicana was obtained from the Texas Water Oriented Data Bank for the years 1968 through 1992. January: Average rainfall = 2.39 in
- 3** Average runoff: Method used to determine average runoff is found in Soil Conservation Service Technical Note No. 210-18-TX5. A curve number (N) of 78 is appropriate for Crockett soils (Hydrologic Group D) with continuous grass. The antecedent moisture condition for Navarro County is Type III.
 $Q = (I - 0.2S)^2 / (I + 0.8S)$, and $S = 1000/N - 10$ where Q = runoff in inches
 I = average rainfall in inches (from Column 2); and S = potential maximum retention after runoff begins. January: $S = 1000/78 - 10 = 2.82$ in. $Q = [2.39 - 0.2(2.82)]^2 / [2.39 + 0.8(2.82)] = 0.72$ in
- 4** Average Infiltrated Rainfall (R_i): Obtained by subtracting the average runoff from the average rainfall
January: R_i (avg) = (2.39 in) - (0.72 in) = 1.67 in
- 5** Evapotranspiration (E); Data obtained from the Texas Board of Water Engineers, Bulletin 6019: "Consumptive Use of Water by Major Crops in Texas," Table 5. For Coastal Bermuda Grass, applied 90% of the listed values for alfalfa as noted on the table. January: (905)(1.0 in) = 0.90 in.
- 6** Required leaching to avoid salinity buildup in soil (L): Equation is from 30 TAC 309.20, Table 1.
 $L = [C_e / (C_1 - C_e)](E - R_i)$, where C_e = electrical conductivity of effluent (provided by applicant); and
 C_1 = maximum allowable conductivity of soil solution obtained from 30 TAC 309.20, Table 3.
If $(E - R_i)$ is less than zero (<0), then $L = 0$
January: $L = [(5.4 \text{ mg/l}) / (12.0 \text{ mg/l} - 5.4 \text{ mg/l})](0.9 \text{ in} - 1.67 \text{ in})$ ($E - R_i < 0$, therefore $L = 0$).
- 7** Total Water Needs: Obtained by adding Evapotranspiration ("E," Column 5) and Required Leaching ("L," Column 6). January: 0.90 in + 0.0 in = 0.90 in
- 8** Effluent needed in root zone: Obtained by subtracting the Average Infiltrated Rainfall (R_i , Column 4) from Total Water Needs (Column 7). If value is less than zero, then a value of zero is assumed.
January: 0.90 in - 1.67 in = -0.77 and $-0.77 < 0$, therefore the amount of effluent needed in the root zone = 0.0 in

- 9** Net evaporation from reservoir surface: Average evaporation data was obtained from the Texas Water Oriented Data Bank for the years 1966 through 1990. Values were multiplied by the ratio of the surface area of the ponds (5.5 acres) to the irrigation surface area (58 acres). For Griffin Industries, the ratio is $5.5/58 = 0.09$. January: $\text{Evap.} = (0.05 \text{ feet})(12 \text{ in/ft})(0.09) = 0.06 \text{ in}$
- 10** Effluent to be applied to land: Obtained by dividing the effluent need in root zone (Column 8) by the irrigation efficiency, K (assumed to be 0.85, or 85%). January: $0.0/0.85 = 0.0 \text{ in}$
- 11** Consumption from reservoir: Obtained by adding the net evaporation from the reservoir surface (Column 9) and the effluent to be applied to the land (Column 10). This is the maximum hydraulic application rate that can be applied over the irrigated area.
January: $0.06 \text{ in} + 0 \text{ in} = 0.06 \text{ inches/acre}$
 Total annual application is 59.96 in per irrigated acre (59.96 in/ac/yr).

TABLE 2:
Column:

12 Month

- 13** Effluent received for application or storage: A daily average flow to the irrigation field of 38,000 gallons was requested by the applicant and converted to in per acre. The average application rate must be less than or equal to the consumption from reservoir (Column 11). Therefore, the maximum monthly average application rate is $(98.9 \text{ in/ac/yr})/(12 \text{ mo/yr}) = 8.24 \text{ in/ac/mo}$
Annual: $= (38,000 \text{ gal/day})(365 \text{ days/yr})(12 \text{ in/ft})(1 \text{ ac}/43,560 \text{ ft}^2)(1 \text{ ft}^3/7.48 \text{ gal})(58 \text{ ac})$
 $= 8.76 \text{ in/ac/yr}$
January: $= 8.76 \text{ in/ac/yr} * (1 \text{ yr}/12 \text{ mo})$
 $= 0.73 \text{ in/ac/mo}$, which is less than 8.24 in/ac/mo calculated in Column 13.
- 14** Worst rainfall year in the past 25 years distributed proportional to monthly averages: Rainfall data for Corsicana was obtained from the Texas Water Oriented Data Bank for the years 1968 through 1992 and distributed proportional to the monthly averages. The worst annual rainfall was 51.9 in which occurred in 1968.
January: $(51.9 \text{ in})(6.4\%) = 3.32 \text{ in}$
- 15** Worst runoff year in the past 25 years (Q): Used the rainfall figures in Column 14 and calculating worst runoff similar to average runoff as in Column 3.
January: $Q = [3.32 \text{ in} - 0.2(2.82)]^2/[3.32 + 0.8(2.82)] = 1.36 \text{ in}$
- 16** Infiltrated rainfall (R_i): Obtained by subtracting the worst runoff year (Column 15) from the worst rainfall year (Column 14).
January: $R_i \text{ (worst)} = 3.32 \text{ in} - 1.36 \text{ in} = 1.96 \text{ in}$
- 17** Available water: Obtained by adding the amount of effluent received for application or storage (Column 13) and the infiltrated rainfall (Column 16).
January: $0.73 \text{ in} + 1.96 \text{ in} = 2.69 \text{ in}$

18 Lowest annual net evaporation in the past 25 years from the reservoir surface: Minimum annual net evaporation data was obtained from the Texas Water Oriented Data Bank for the years 1966 through 1990 and distributed proportional to monthly averages. Values were then multiplied by the ratio of the surface area of the ponds (5.5 acres) to the irrigation surface area (58 acres). For Griffin Industries, the ratio is $5.5/58 = 0.09 = 0.04$ in

19 Storage: Obtained by calculating according to 30 TAC 309.20, Table 2.

$$\text{Storage} = [(\text{Column 13} - \text{Column 18B}) - [(\text{Column 7} - \text{Column 16})/k]$$

If $[(\text{Column 7} - \text{Column 16})/k] < 0$, it is entered as zero, and Storage = (Column 13 - Column 18)

January: Storage = $(0.73 - 0.036) - [(0.9 - 0)/0.85] = -0.37$ in

20 Accumulated Storage: To allow for the worst condition, the summation of storage was obtained by adding the values obtained in Column 19, beginning with the first consecutive month of positive values. In this case, the summation was started in November. The maximum accumulated storage requirement occurred in February.

Annual: $(0.61 \text{ in}) + (0.67 \text{ in}) + 0.69 \text{ in} = (0.70 \text{ in}) = 2.67 \text{ in-ac/ac}$

MONTHLY WATER BALANCE, TABLE 1 ⁽¹⁾
(Units in Inches)

1	2	3	4	5	6	7	8	9	10	11
	AVG RAIN	AVG RUN-OFF	AVG INFILTRATED RAINFALL	EVAPO-TRANSPIRATION	REQUIRED LEACHING	TOTAL WATER NEEDS	EFFLUENT REQ'D IN ROOT ZONE	EVAPORATION FROM RESERVOIR SURFACE	EFFLUENT APPLIED TO LAND	CONSUMPTION FROM RESERVOIR
JAN	2.39	0.72	1.67	0.9	0.0	0.9	0.0	0.06	0.0	0.06
FEB	2.80	0.99	1.81	1.3	0.0	1.3	0.0	0.03	0.0	0.03
MAR	2.95	1.09	1.86	3.0	0.9	3.9	2.1	0.15	2.5	2.6
APR	4.04	1.92	2.12	3.5	1.1	4.6	2.5	0.11	3.0	3.1
MAY	5.10	2.80	2.30	6.5	3.4	9.9	7.6	0.16	9.0	9.1
JUN	3.04	1.16	1.88	6.7	3.9	10.6	8.8	0.39	10.3	10.7
JUL	2.24	0.62	1.62	7.4	4.7	12.1	10.5	0.64	12.4	13.0
AUG	2.21	0.61	1.60	5.1	2.9	8.0	6.4	0.66	7.5	8.1
SEP	2.97	1.11	1.86	5.3	2.8	8.1	6.3	0.42	7.4	7.8
OCT	3.43	1.44	1.99	4.2	1.8	6.0	4.0	0.31	4.7	5.0
NOV	2.97	1.11	1.86	1.7	0.0	1.70	0.0	0.16	0.0	0.16
DEC	3.31	1.35	1.96	0.72	0.0	0.72	0.0	0.08	0.0	0.08
TOTAL	37.45	14.92	22.53	46.3	21.5	67.8	48.2	3.16	56.8	59.7

⁽¹⁾ Table 1 was completed in accordance with Table 1 of 30 TAC 309.20. Refer to Appendix C for detailed explanation of calculations.

STORAGE VOLUME CALCULATION, TABLE 2 ⁽¹⁾
(Units in Inches)

12	13	14A	14B	15	16	17	18A	18B	19	20
	EFFLUENT APPLIED TO LAND (INCHES)	MEAN RAINFALL DISTRIBUTION (%)	RAINFALL (MAX) (INCHES)	RUNOFF (MAX) (INCHES)	INFILTRATED RAINFALL (INCHES)	TOTAL AVAIL. H ₂ O (INCHES)	% DISTRIBUTION OF MEAN	NET EVAPORATION (MIN) (INCHES)	STORAGE (IN-AC/AC)	ACCUMULATED STORAGE (IN-AC/AC)
JAN	0.73	6.4	3.32	1.36	1.96	2.69	1.8 %	0.02	0.69	1.98
FEB	0.73	7.5	3.89	1.80	2.09	2.82	1.1%	0.024	0.71	2.69
MAR	0.73	7.9	4.10	1.97	2.16	2.86	4.7 %	0.10	-1.4	1.27
APR	0.73	10.8	5.61	3.23	2.37	3.10	3.6 %	0.08	-2.0	-0.73
MAY	0.73	13.6	7.06	4.53	2.53	3.26	4.9 %	0.11	-8.1	-8.83
JUN	0.73	8.1	4.20	2.05	2.15	2.88	12.4 %	0.27	-9.5	-18.33
JUL	0.73	6.0	3.11	1.21	1.90	2.63	20.0 %	0.43	-11.7	-30.13
AUG	0.73	5.9	3.06	1.17	1.89	2.62	20.8 %	0.46	-6.9	-37.03
SEP	0.73	7.9	4.10	1.97	2.13	2.86	13.2 %	0.29	-6.6	-43.63
OCT	0.73	9.2	4.77	2.52	2.25	2.98	9.6 %	0.21	-3.9	-47.53
NOV	0.73	7.9	4.10	1.97	2.13	2.86	5.1 %	0.11	0.62	0.62
DEC	0.73	8.8	4.57	2.35	2.22	2.95	2.6 %	0.06	0.67	1.29
TOTAL	8.76	100.0	51.9	26.1	25.8	34.5	100	2.18	-----	2.67⁽²⁾

⁽¹⁾ Table 2 was completed in accordance with Table 2 of 30 TAC 309.20. Refer to Appendix C for detailed explanation of calculations.

⁽²⁾ Storage volume requirement = 2.69 in-ac/ac, = (2.69 in-ac/ac)(58 ac)(1 ft/12 in)= 13 ac-ft